

Western
Wood
Products
Association

Standard Patterns



STANDARD PATTERNS

CONTENTS

Paneling	4
Paneling and Siding	6
Siding	7
Ceiling	12
Ceiling and Partition	13
Partition	14
Shiplap	15
Tongued & Grooved	16
Decking	16
Decking and Flooring	20
Flooring	21
Corn Cribbing	22
Grooved Roofing	22
Patent Lath	22
Stile	22
Sill	22
Jamb	22
Ogee Batten	23
Casket Stock	23
Beaded Shelving	23
Unseasoned Tongued & Grooved	24
Unseasoned Shiplap	24
Coverage Estimator	27
Siding Specification Checklist	27
Grade Selector Chart	back cover

All patterns depicted in this publication are drawn to scale and printed at 70% actual size.

STANDARD PATTERNS LUMBER ABBREVIATIONS

BEV	Beveled
BEV SDG	Beveled siding
BS	Both sides
CB	Center Beaded
CB1S	Center bead one side
CB2S	Center bead two sides
CG	Center groove
CG2E	Center groove two edges
CLG	Ceiling
CM	Center matched
CS	Caulking seam
CSG	Casing
CV	Center Vee
CV1S	Center vee one side
CV2S	Center vee two sides
D2S	Dressed two sides
D4S	Dressed four sides
DB CLG	Double-beaded ceiling
DB PART	Double-beaded partition
DBL T&G	Double tongued & grooved
D&CM	Dressed & center matched
DKG	Decking
D/S,DS	Drop Siding
D S/L	Double shiplap
DVJM	Double vee-jointed matching
D&M	Dressed and matched
E	Edge
EB1S	Edge bead one side
EB2S	Edge bead two sides
E&CB2S	Edge & center bead two sides
EV1S	Edge vee one side
EV2S	Edge vee two sides
E&CV1S	Edge & center vee one side
E&CV2S	Edge & center vee two sides
EE	Eased Edges
EG	Edge (vertical) grain
EM	End matched
EV	Edge vee
FE	Feathered edge
FG	Flat (slash) grain
FLG	Flooring
F&G	Feathered & grooved
G1E	Grooved one edge
HB	Hollow back
MG	Mixed Grain
N	Nosed

N1E	Nosed one edge
N2E	Nosed two edges
OS	One side
PAT	Pattern
P1E	Planed one edge
P2E	Planed two edges
P1S	Planed one side
P2S	Planed two sides
P4S	Planed four sides
P1S1E	Planed one side one edge
P2S1E	Planed two sides one edge
P1S2E	Planed one side two edges
PAR	Planed all 'round
PART	Partition
PE	Planed edge
PPE	Planed plain edge
PSE	Planed square edge
PSJ	Planed and square jointed
PTG	Planed tongued and grooved
R&B	Rabbit & bead
S	Side, Surfaced
SB1S	Single bead one side
SDG	Siding
SG	Slash (flat) grain
S/L, or SL	Shiplap
SQ	Square
STPG	Stepping
S&E	Side & edge (surfaced on)
S1E	Surfaced one edge
S2E	Surfaced two edges
S1S	Surfaced one side
S4S	Surfaced four sides
S1S&CM	Surfaced one side & center matched
S2S&CM	Surfaced two sides & center matched
S4S&CS	Surfaced four sides & caulking seam
S1S1E	Surfaced one side one edge
S1S2E	Surfaced one side two edges
S2S1E	Surfaced two sides one edge
S4SEE	Surfaced four sides eased edges
T&G	Tongued and grooved
TG&B	Tongued, grooved, and beaded
TG&V	Tongued, grooved, and vee-jointed
T1E	Tongued one edge
UE	Unedged
VG	Vertical grain
VJM	Vee-joint matching

Paneling

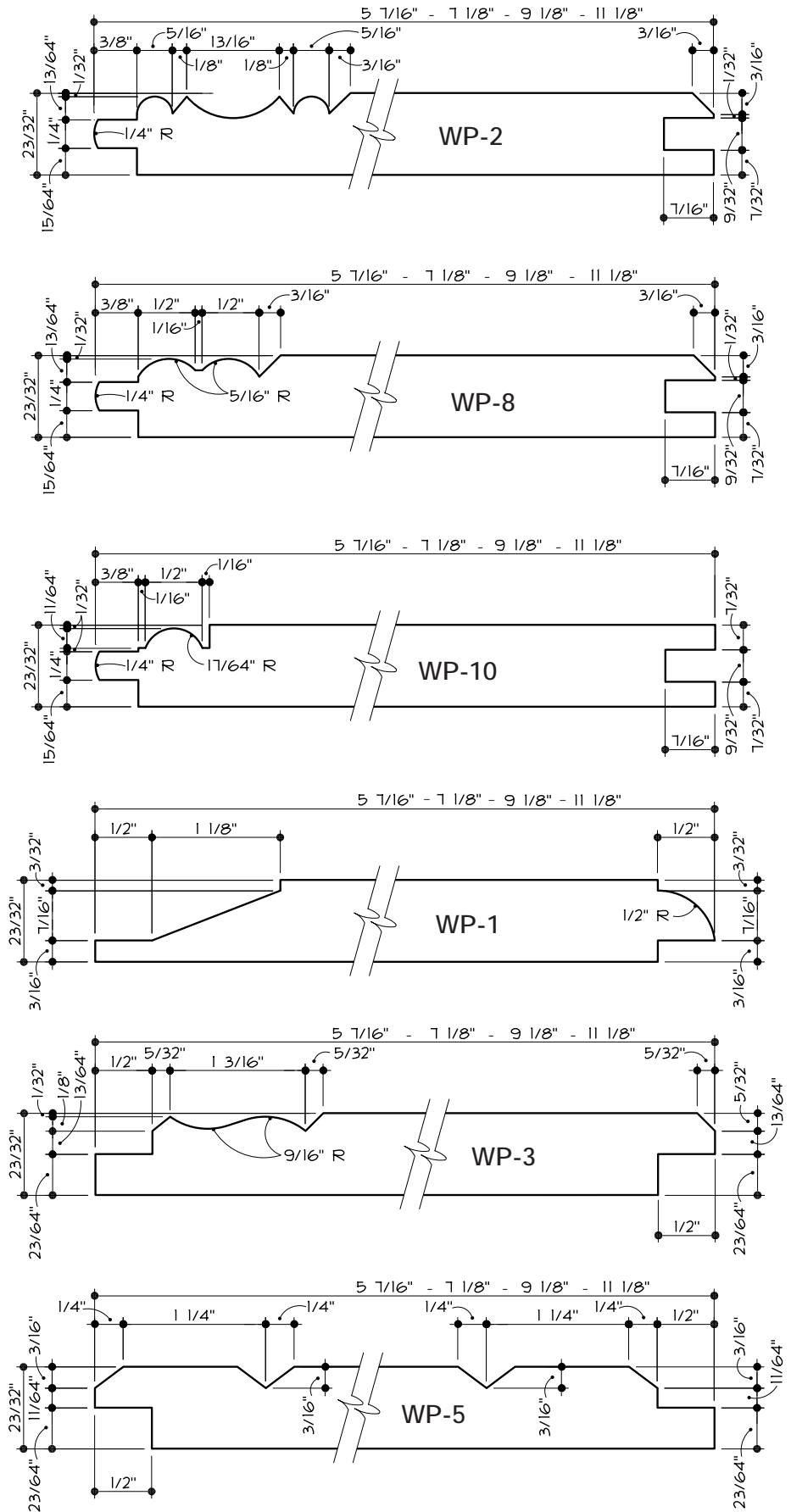

Paneling

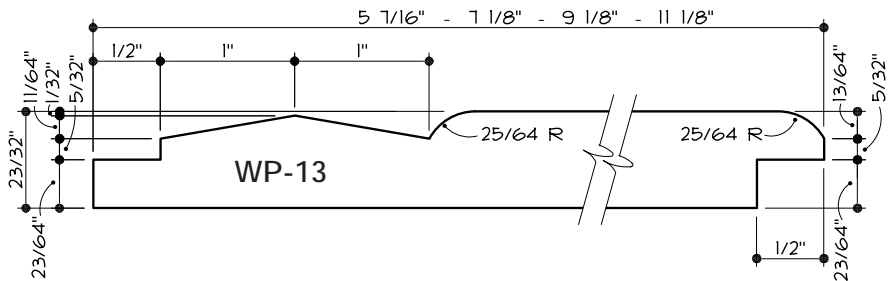
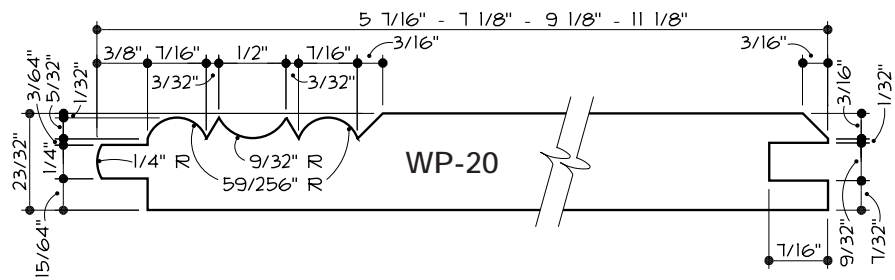
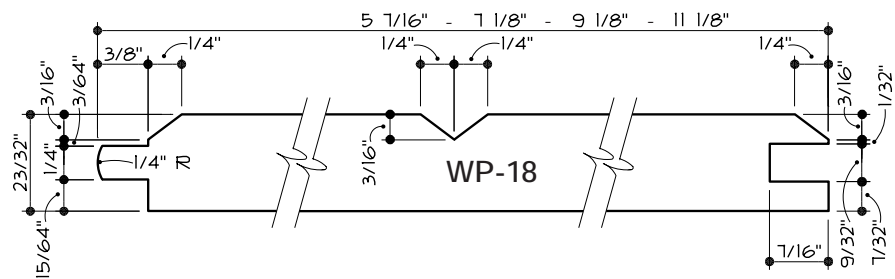
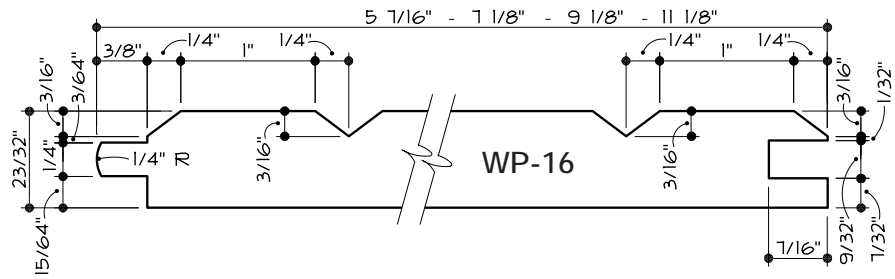
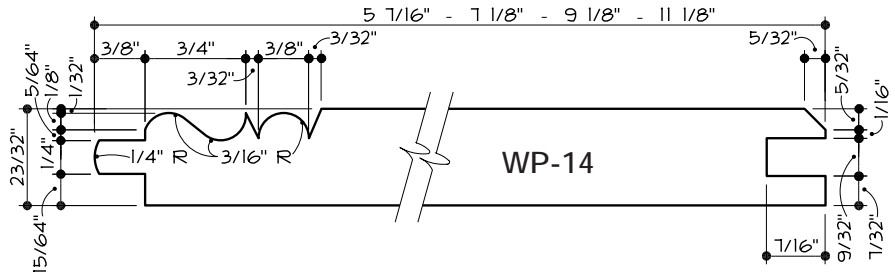
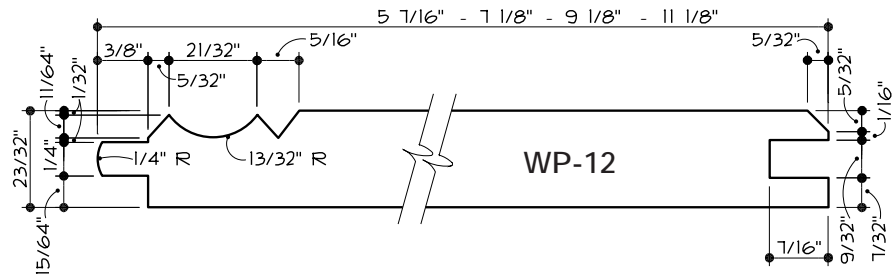

Paneling and Siding

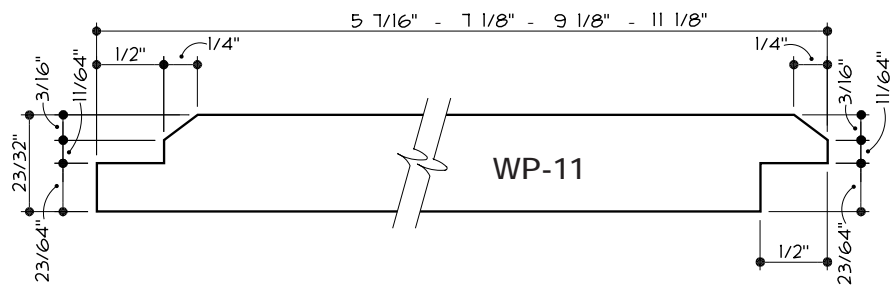
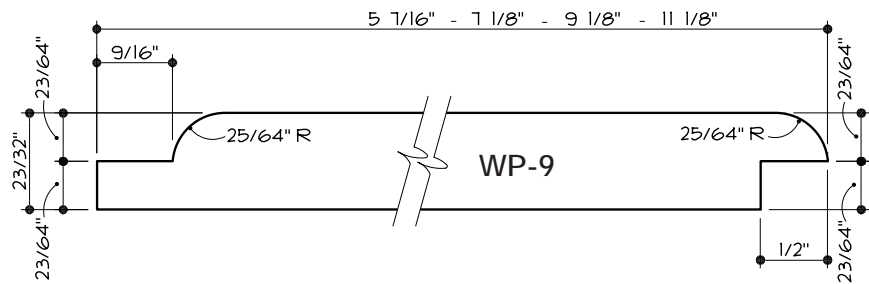
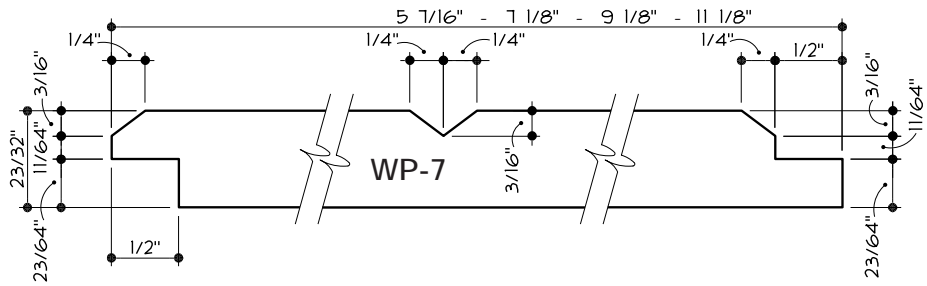
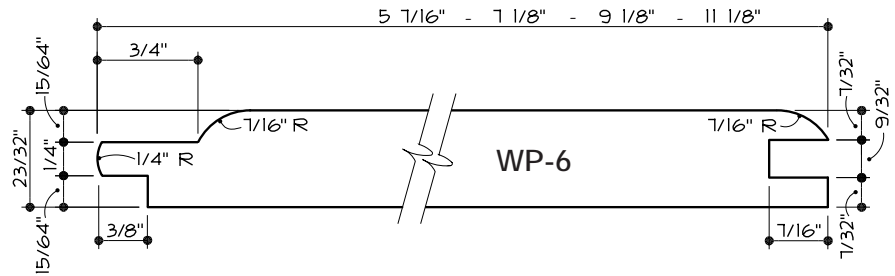
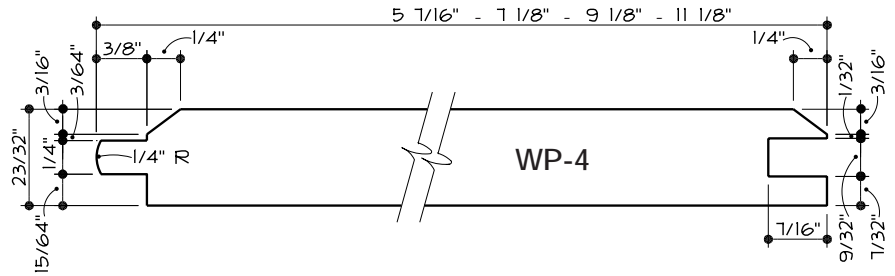
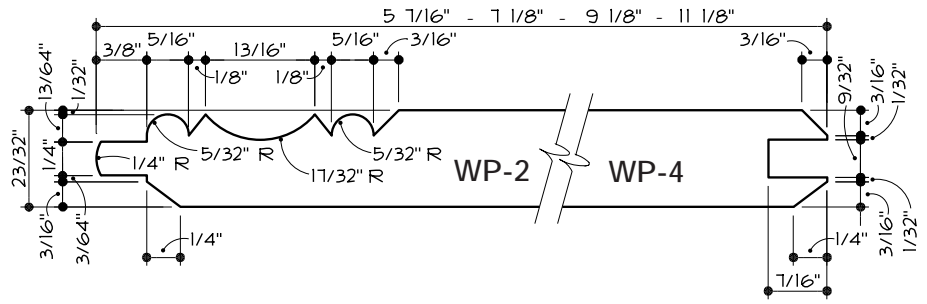

Siding

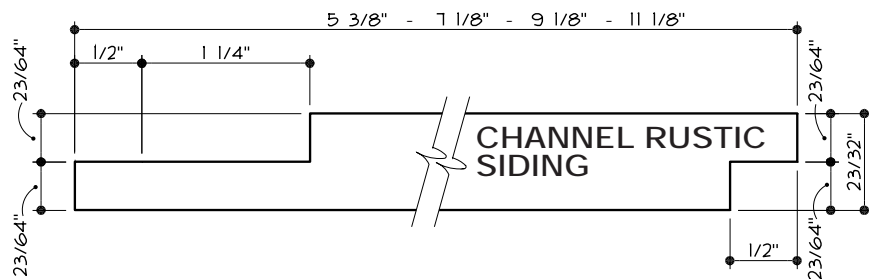
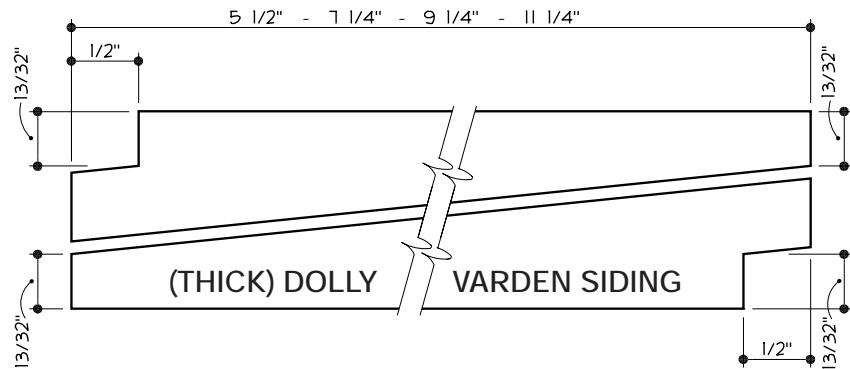
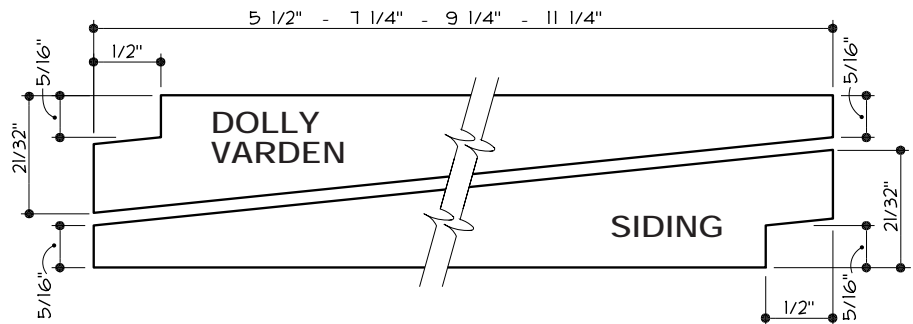
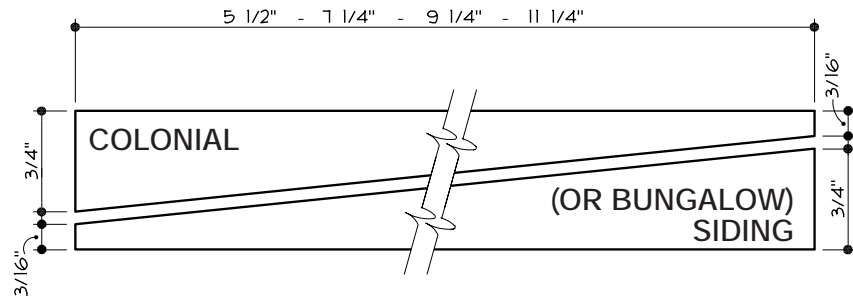
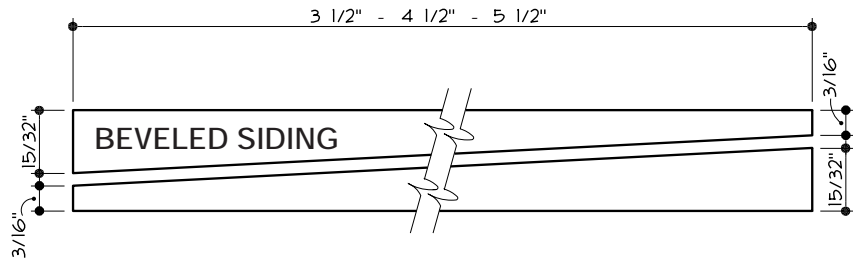

Siding

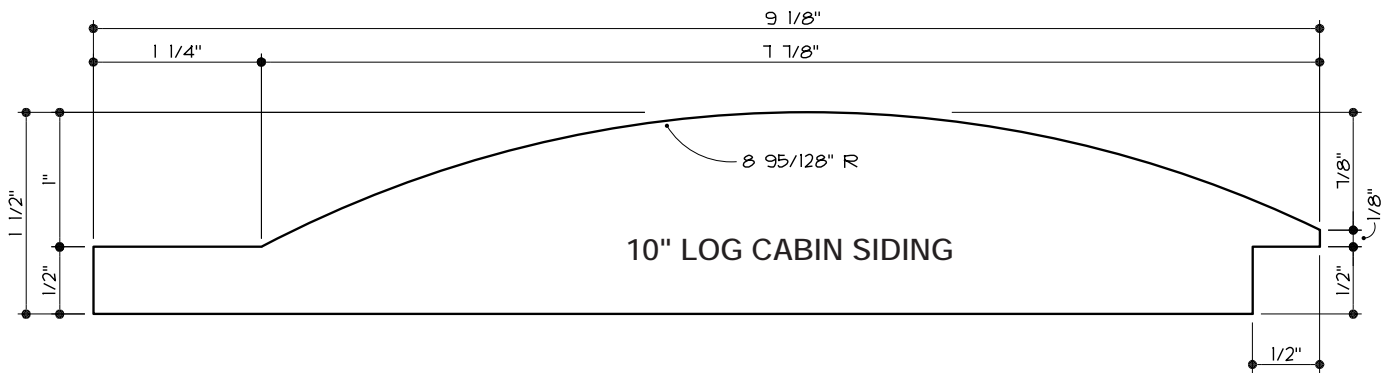
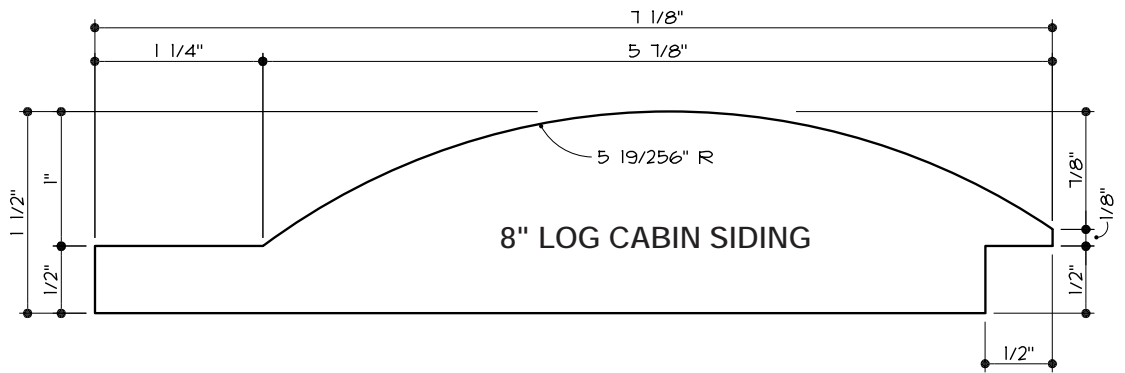
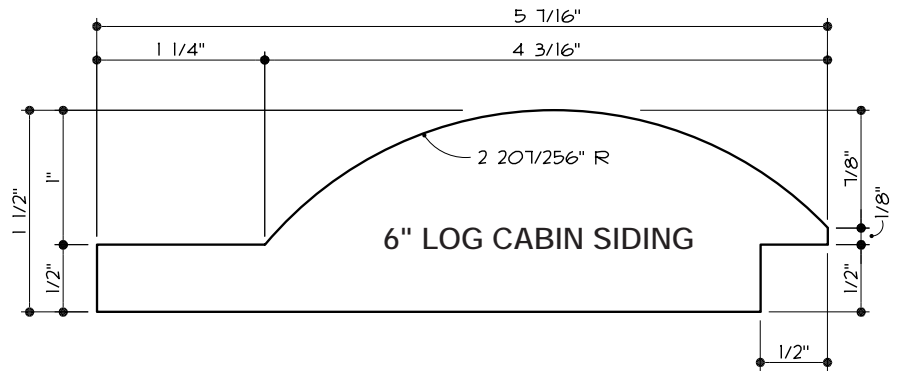

Siding

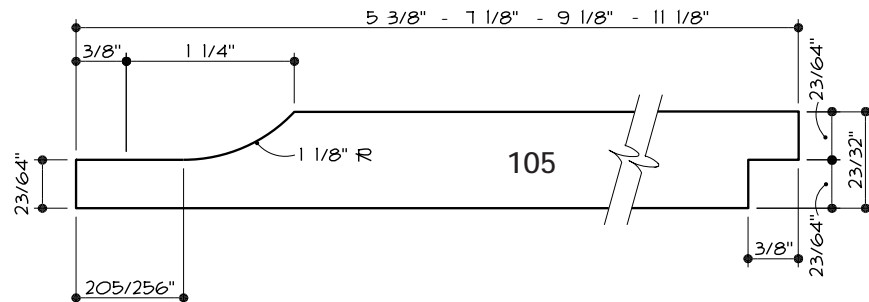
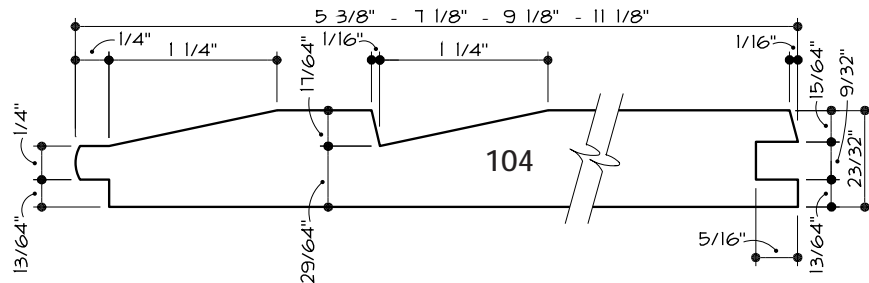
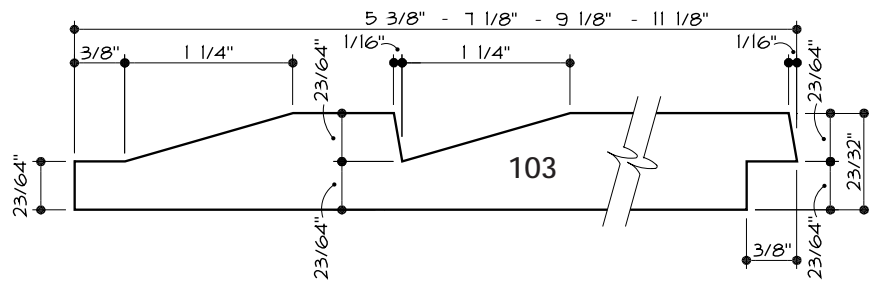
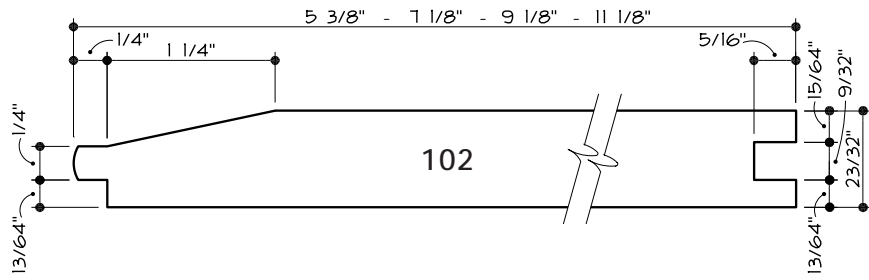
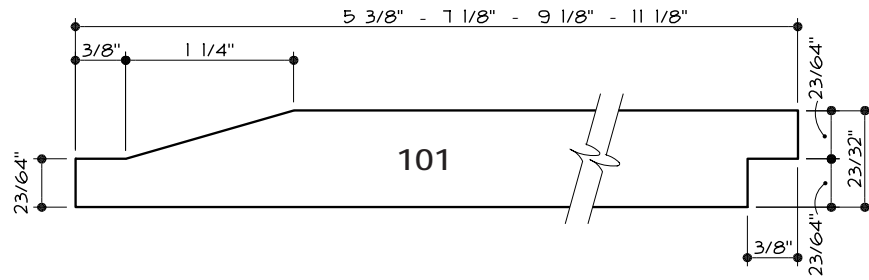

Siding

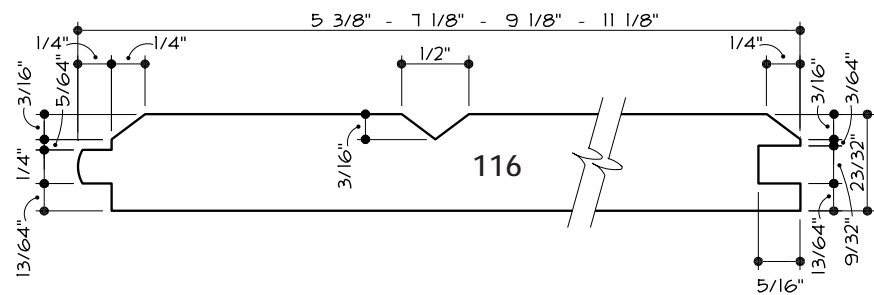
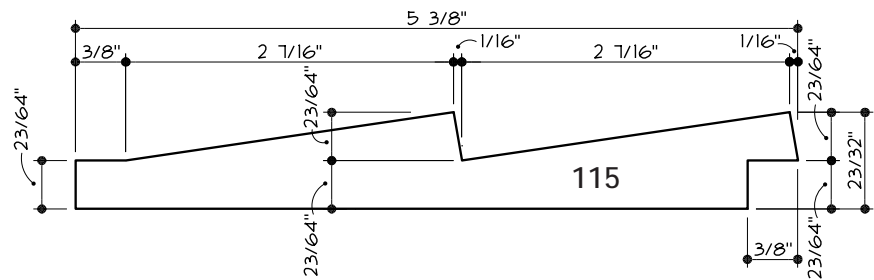
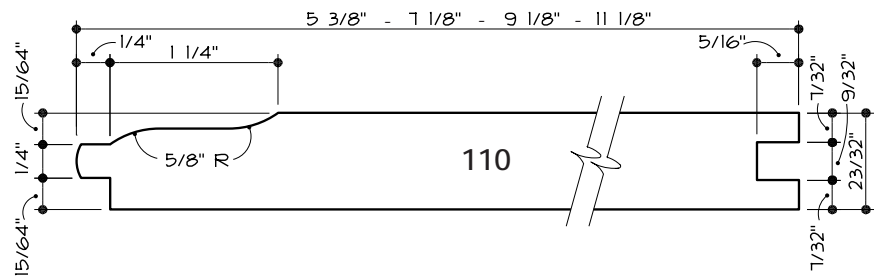
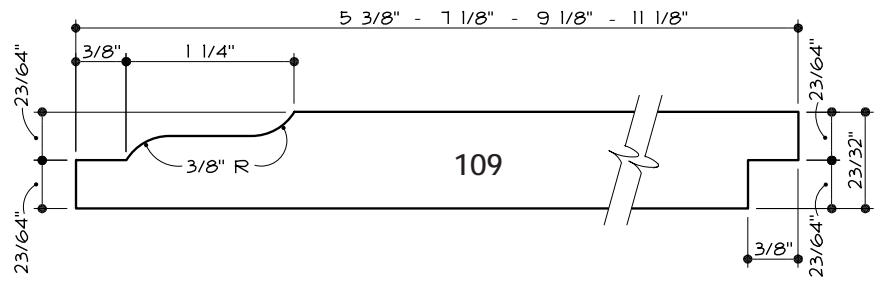
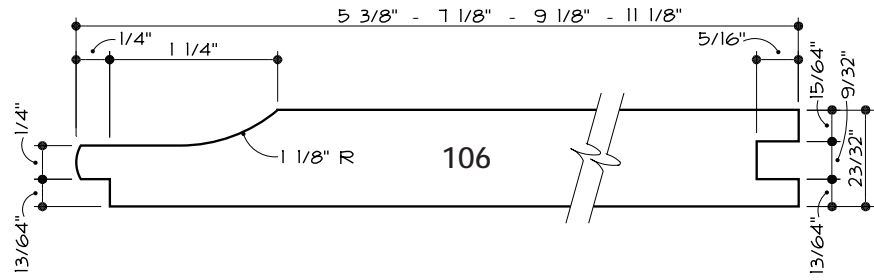

Siding

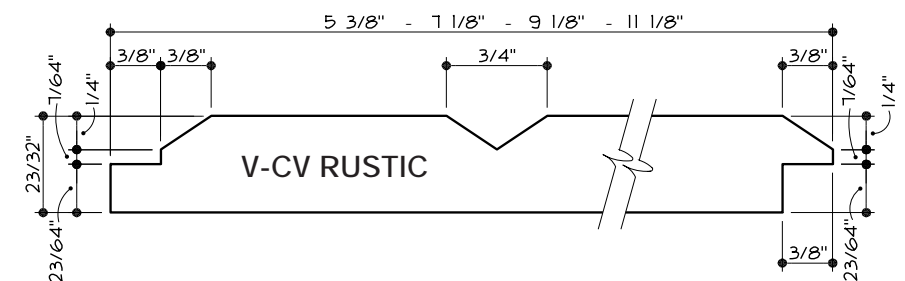
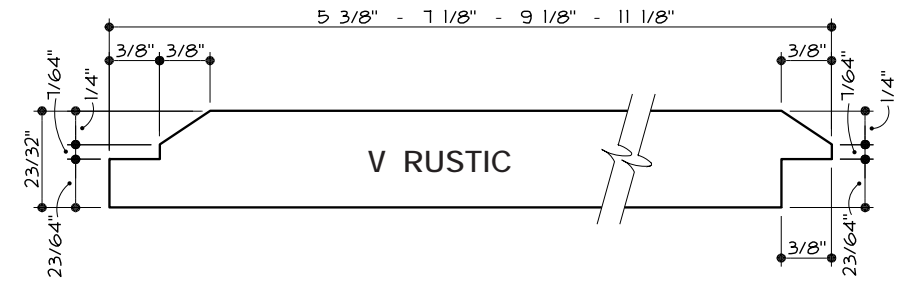
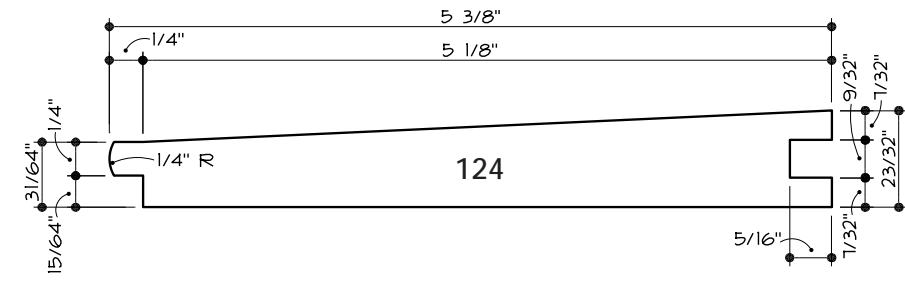
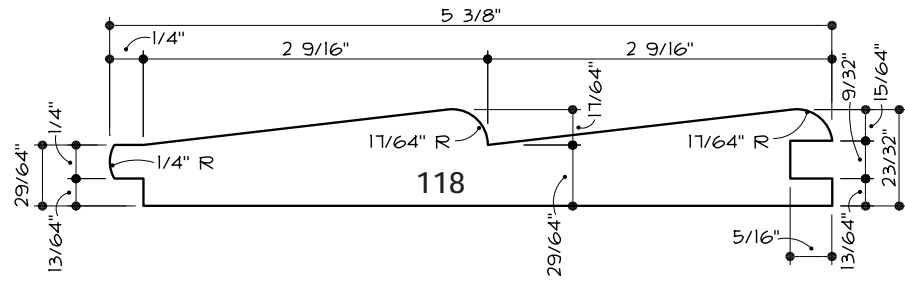
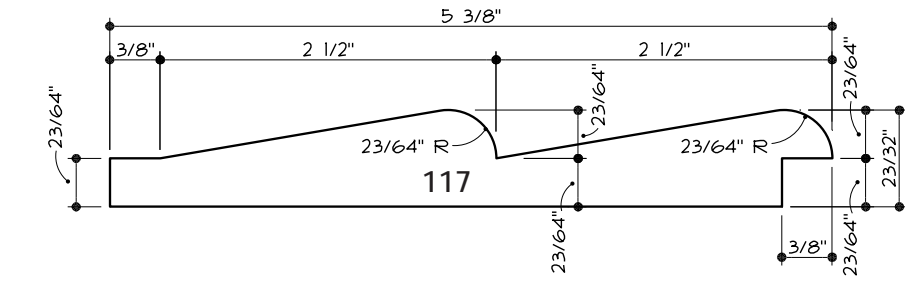

Ceiling

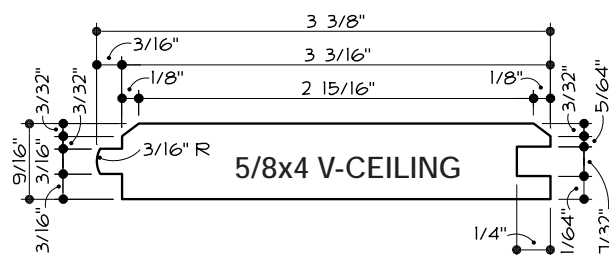
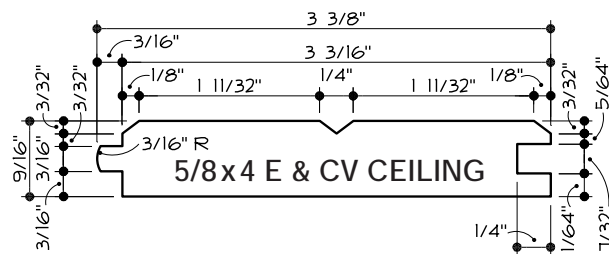
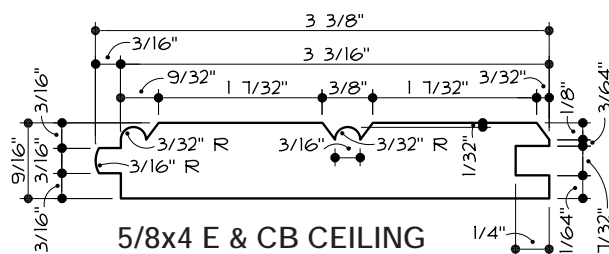
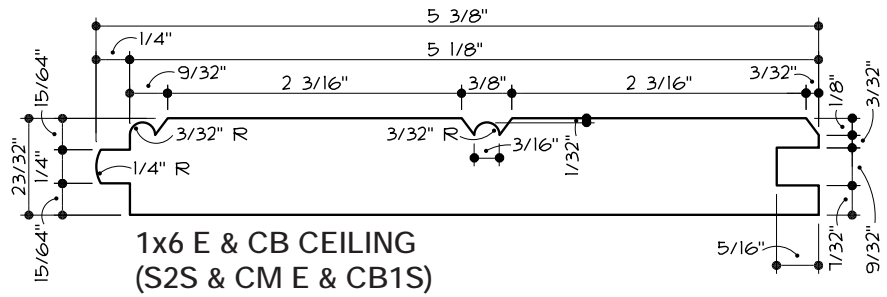
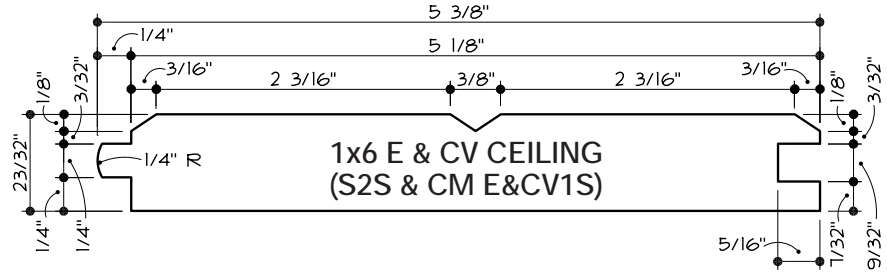
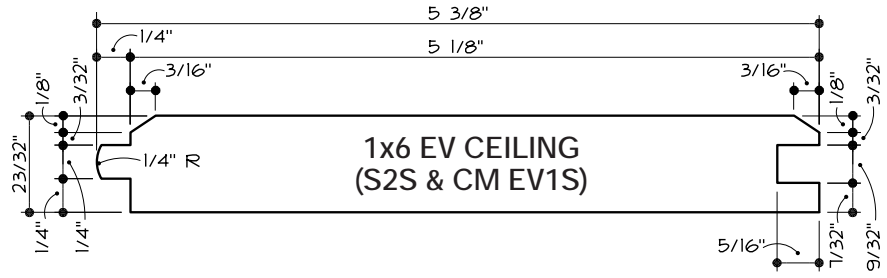

Ceiling and Partition

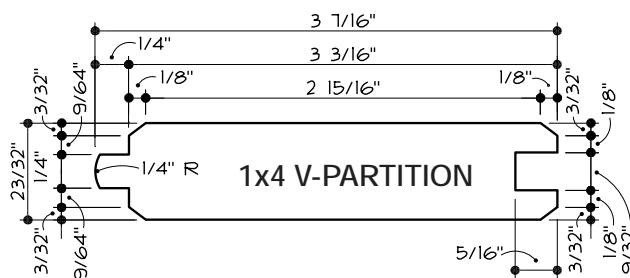
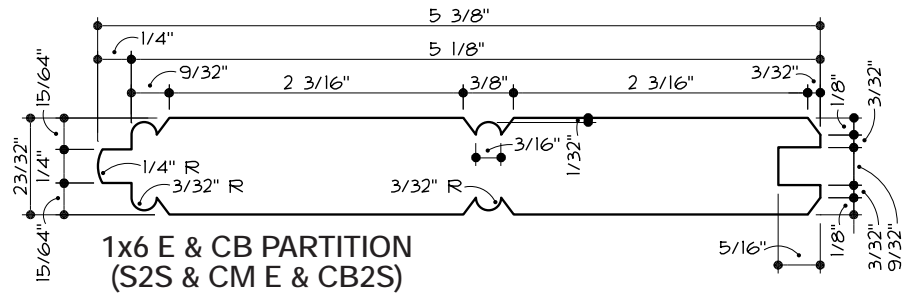
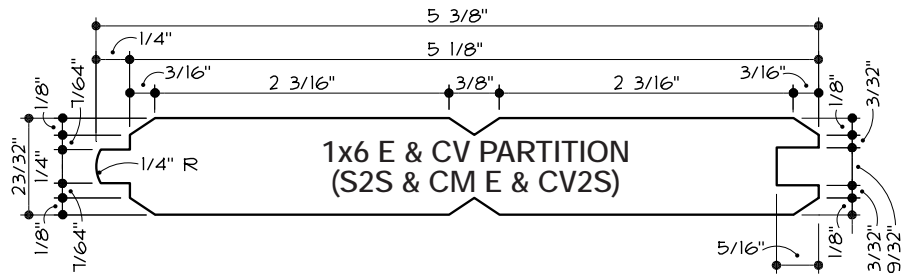
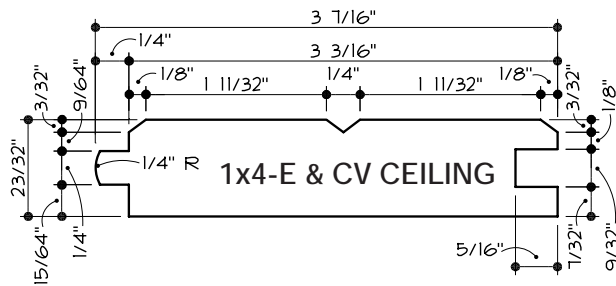
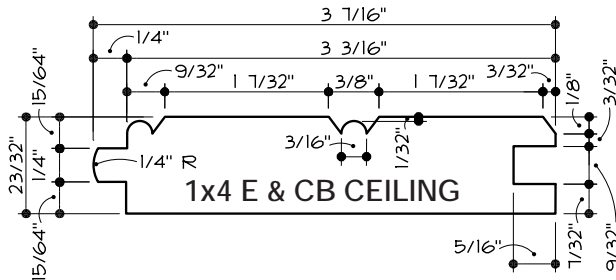
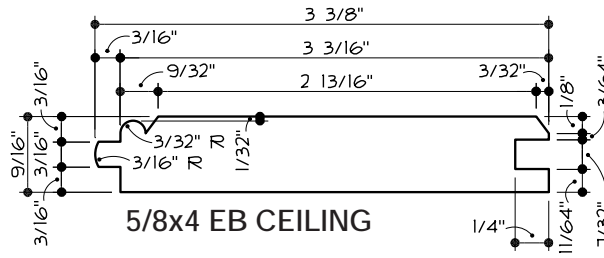

Partition

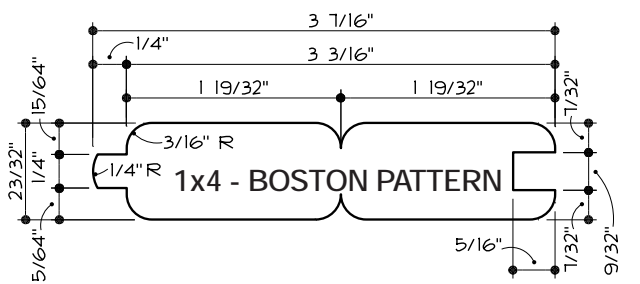
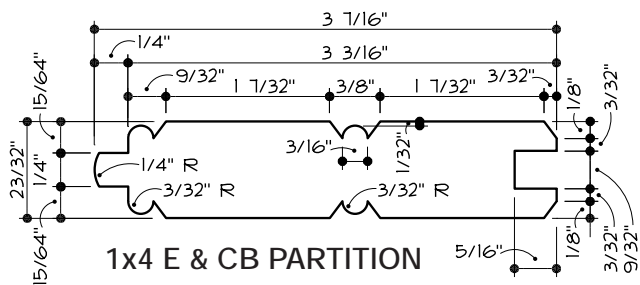
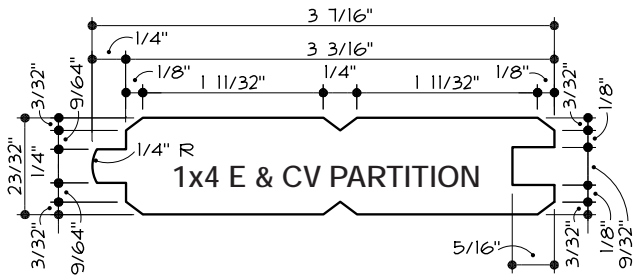
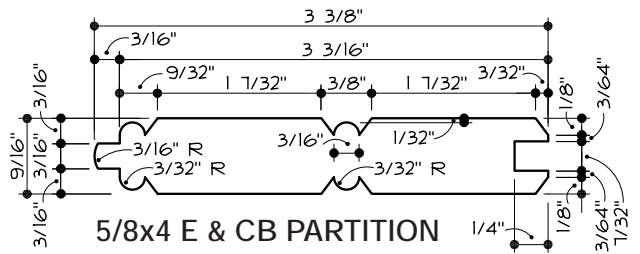
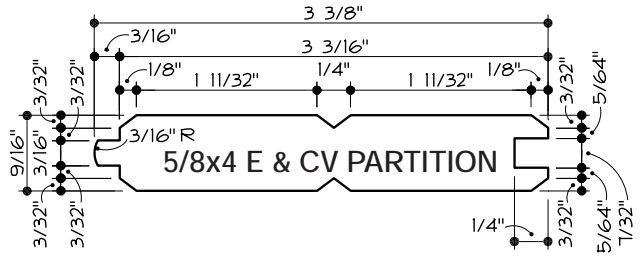
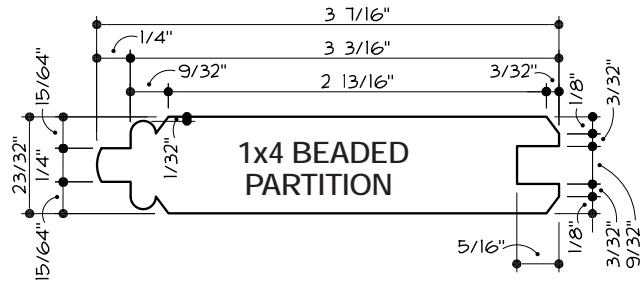

Shiplap

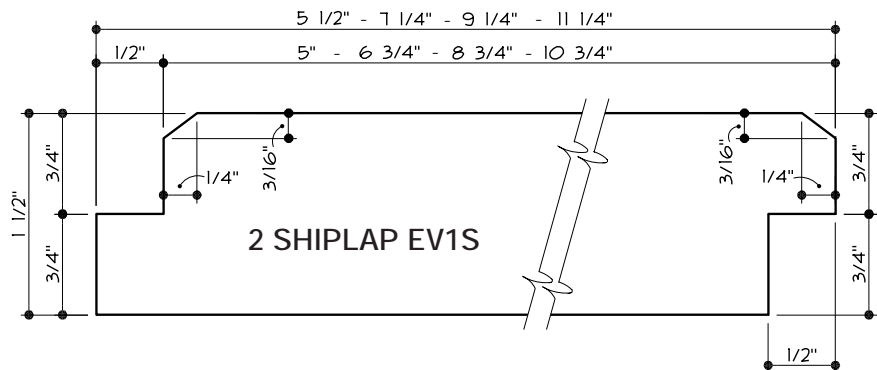
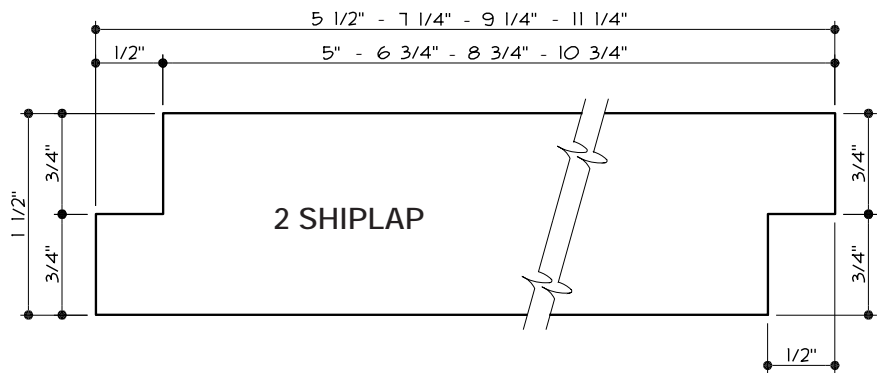
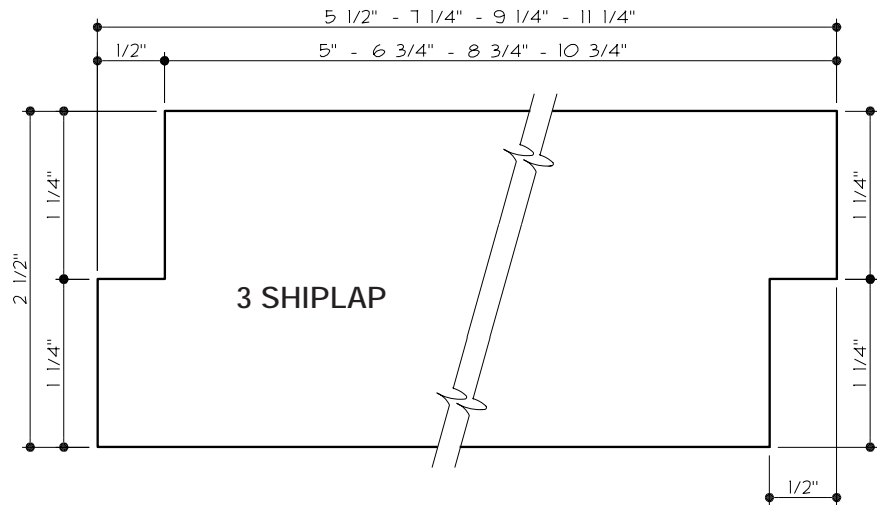
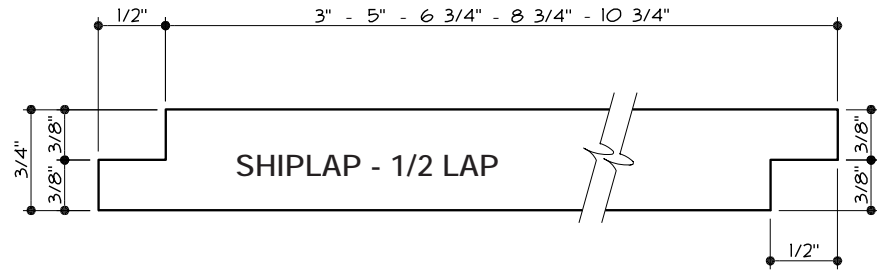
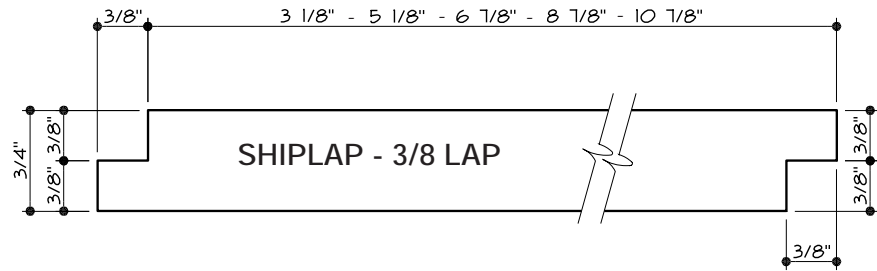

Tongued & Grooved, Decking

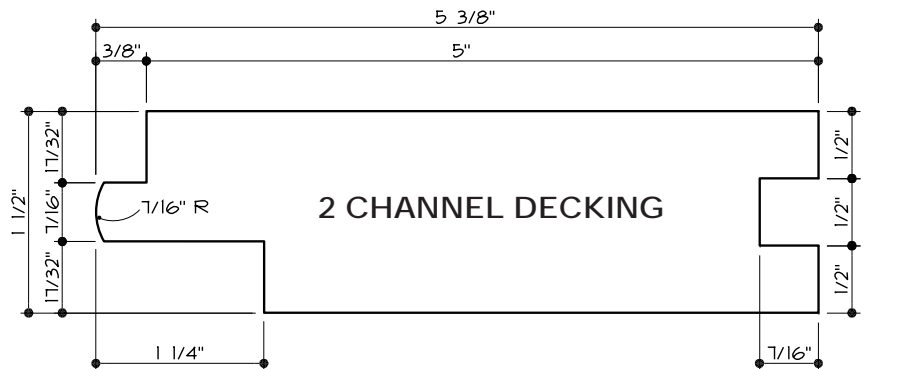
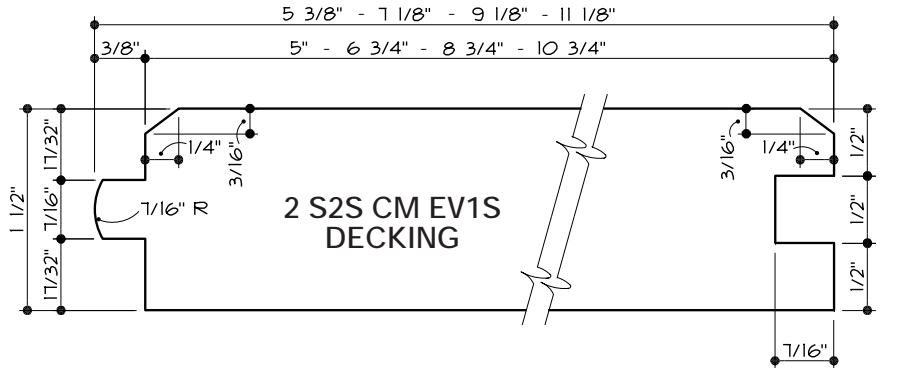
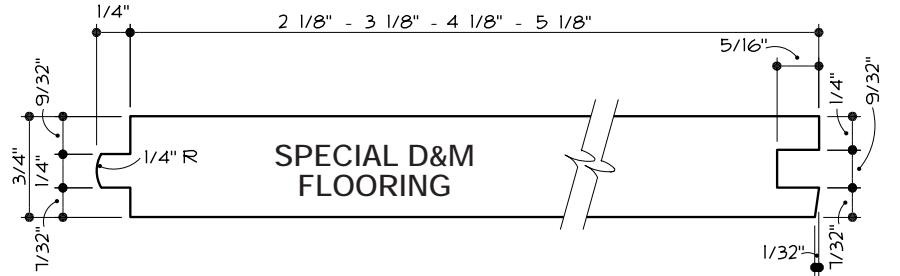
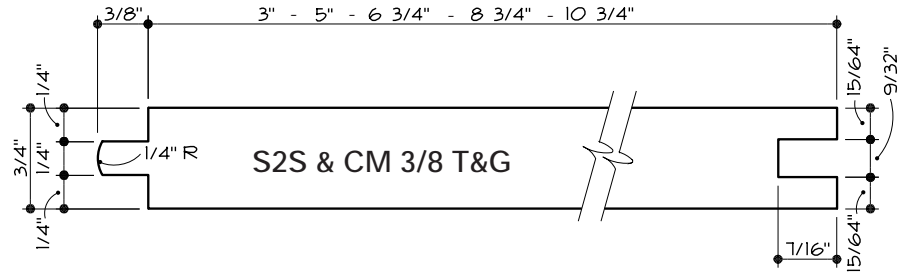
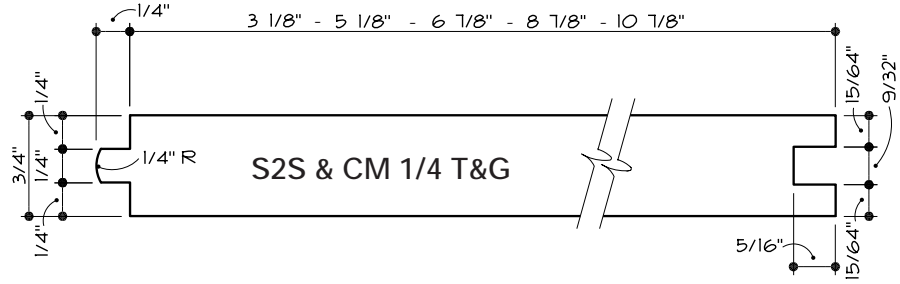

Decking

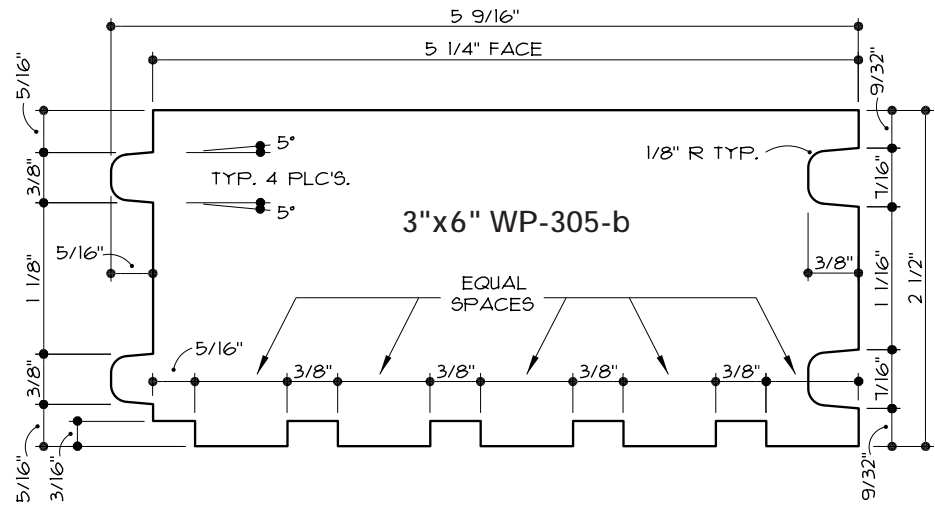
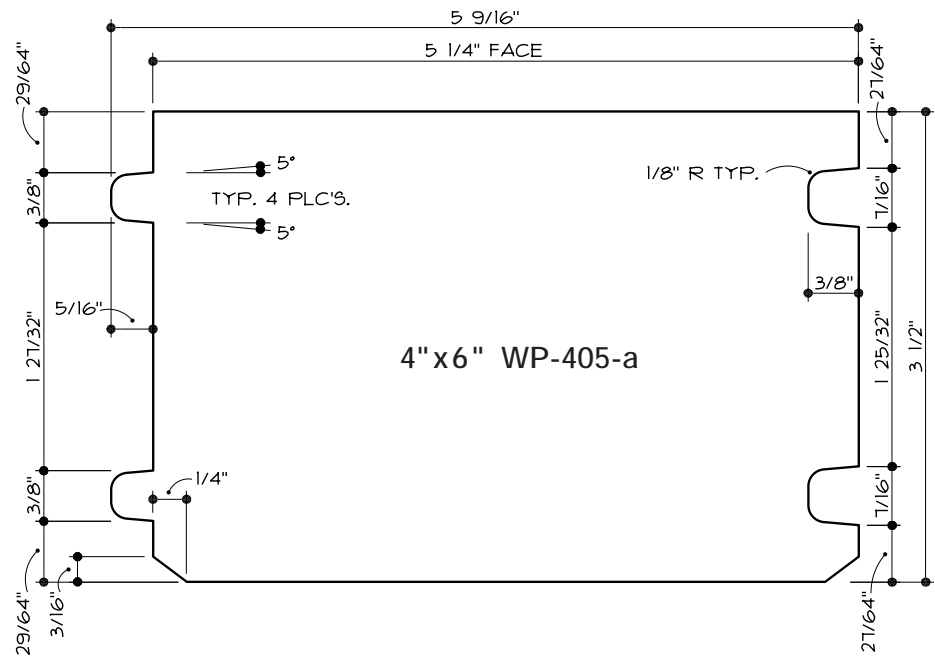
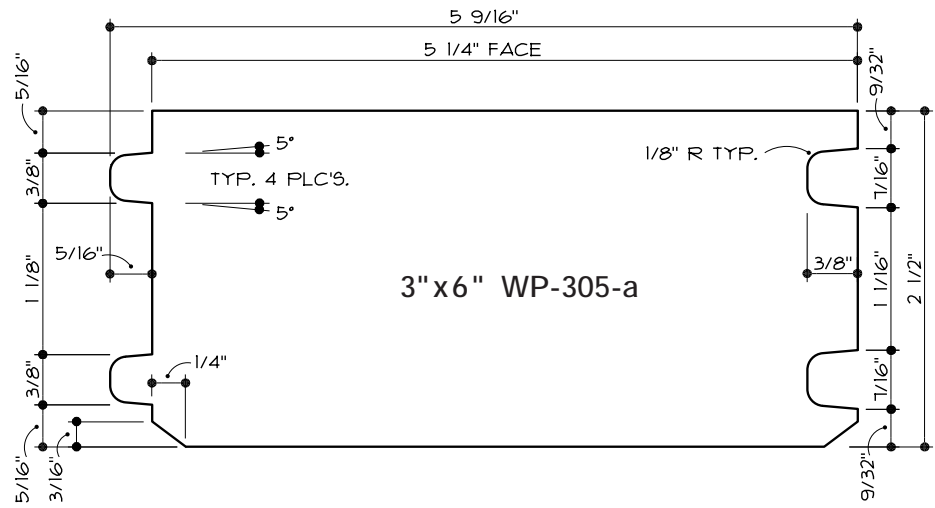

Decking

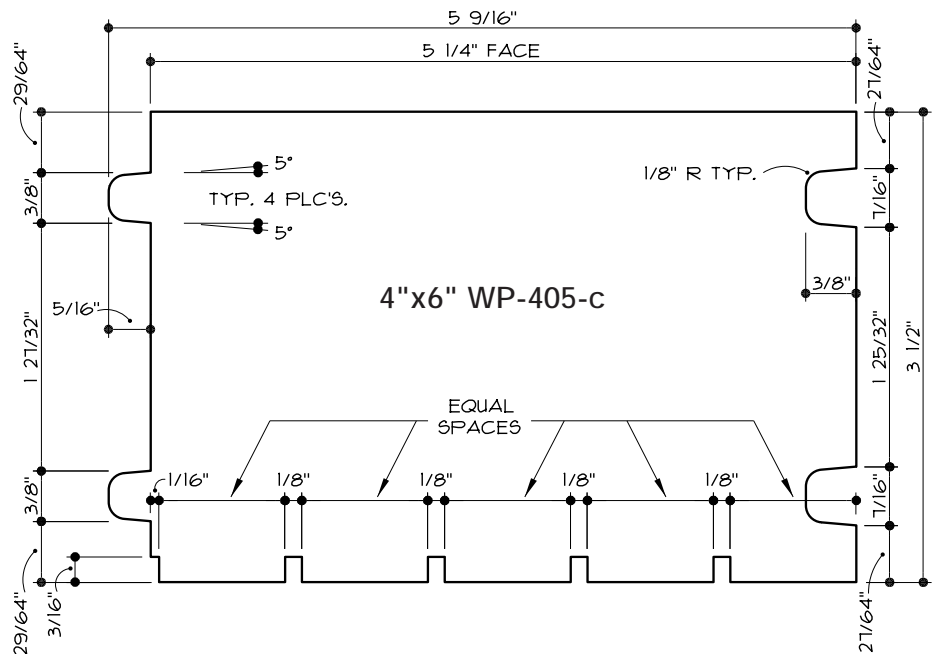
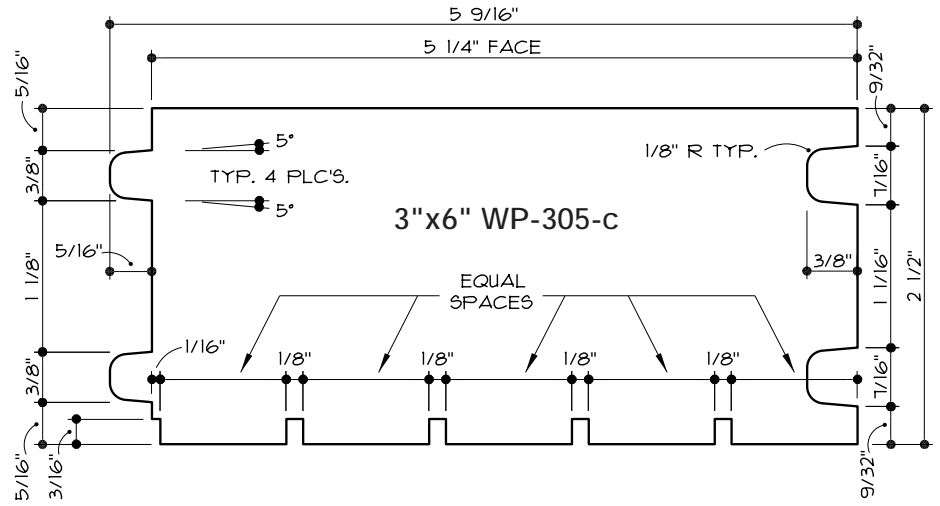
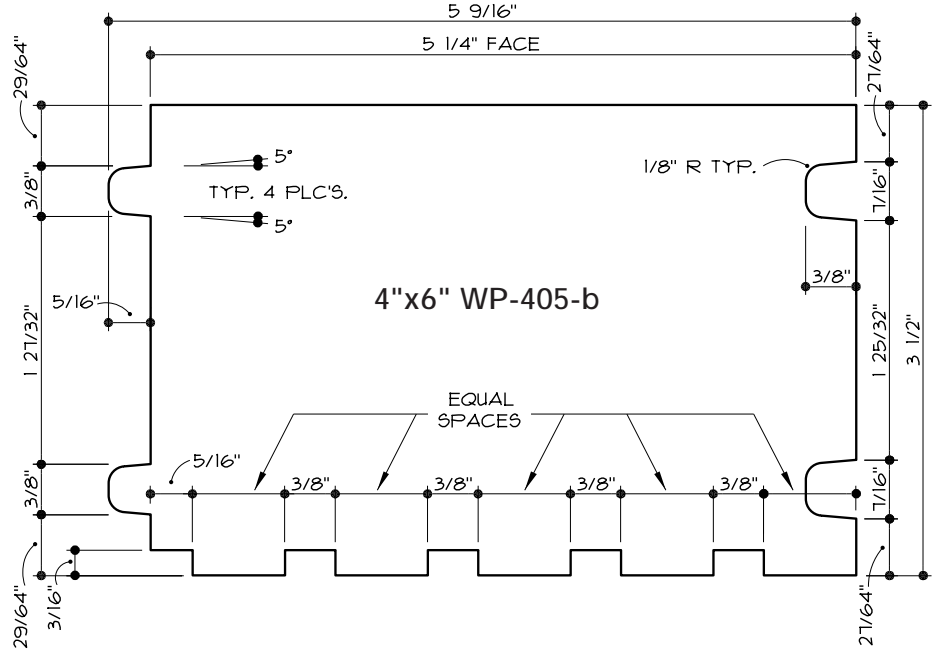

Decking

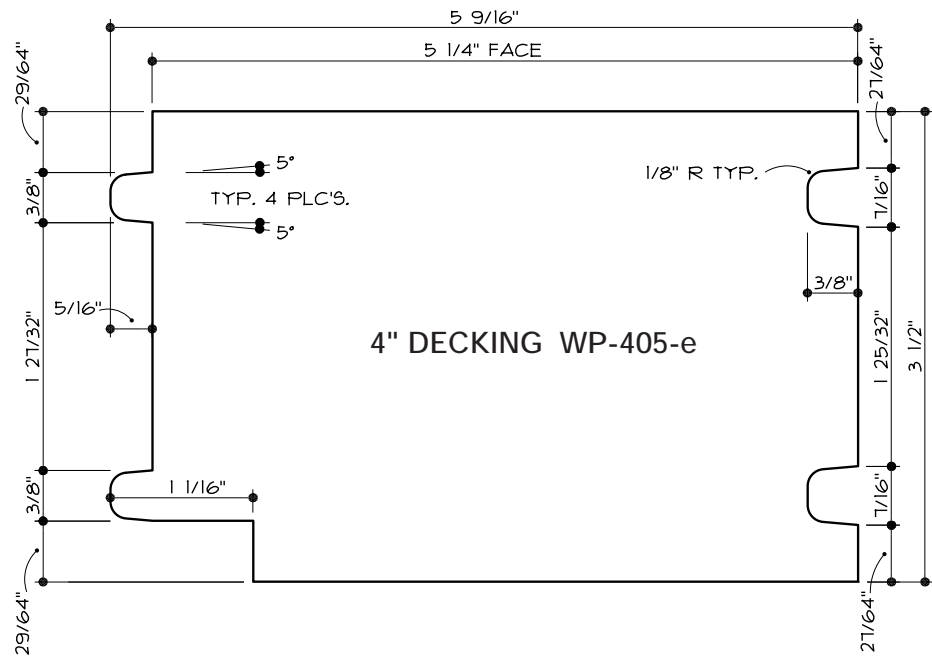
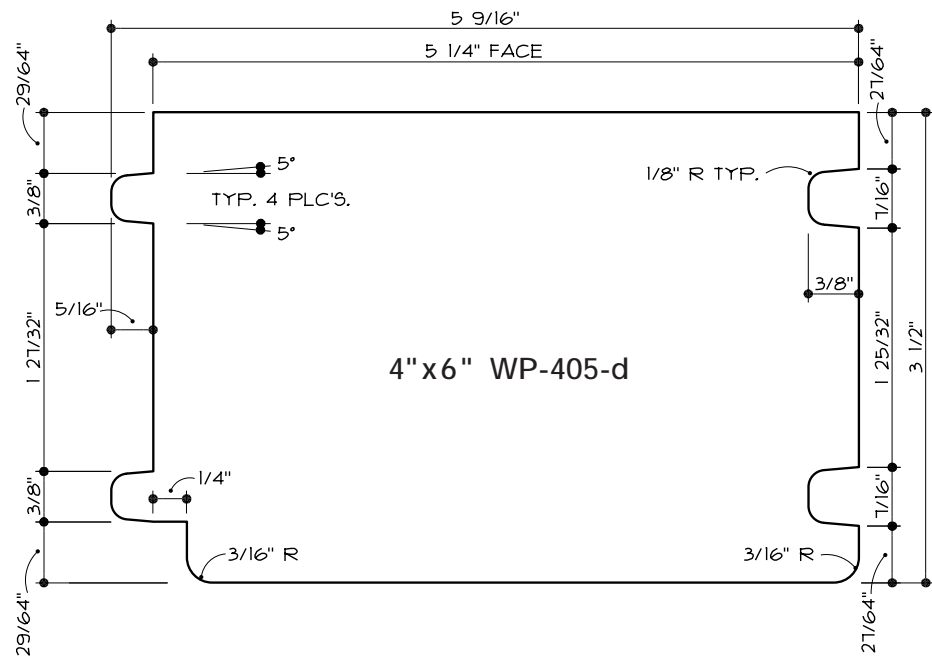
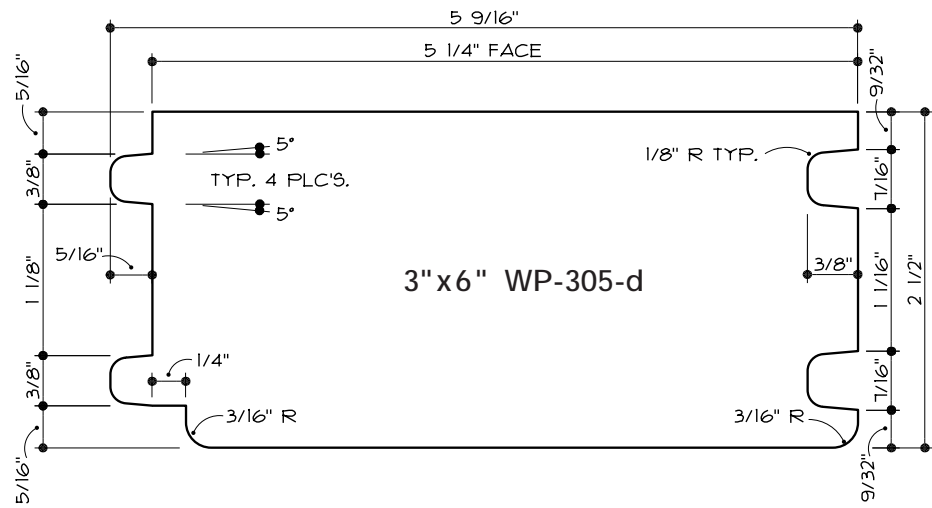

Decking and Flooring

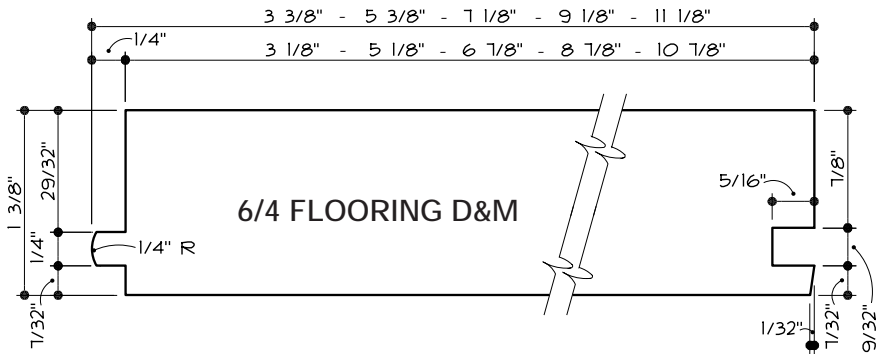
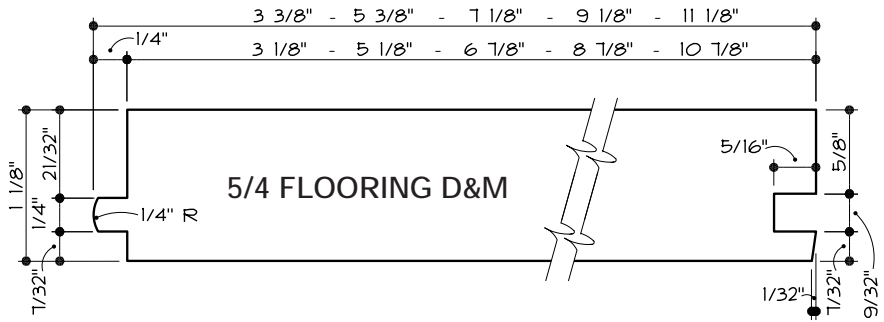
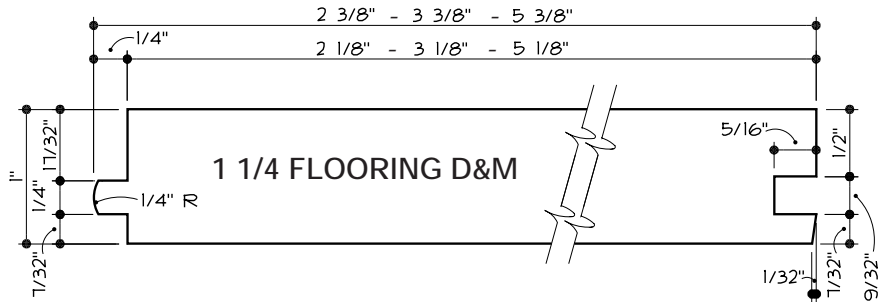
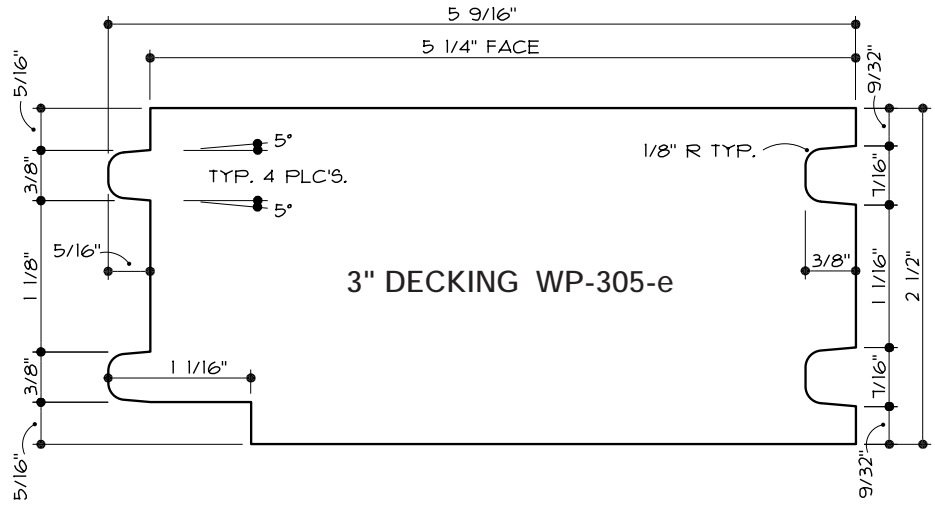

Flooring

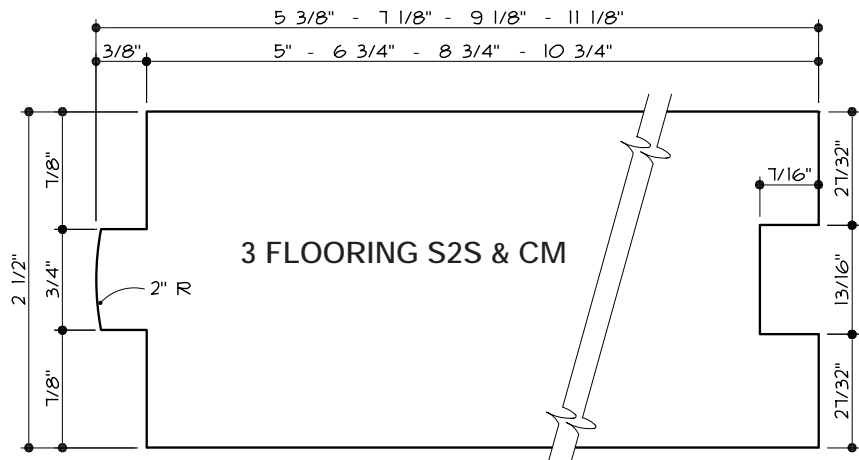
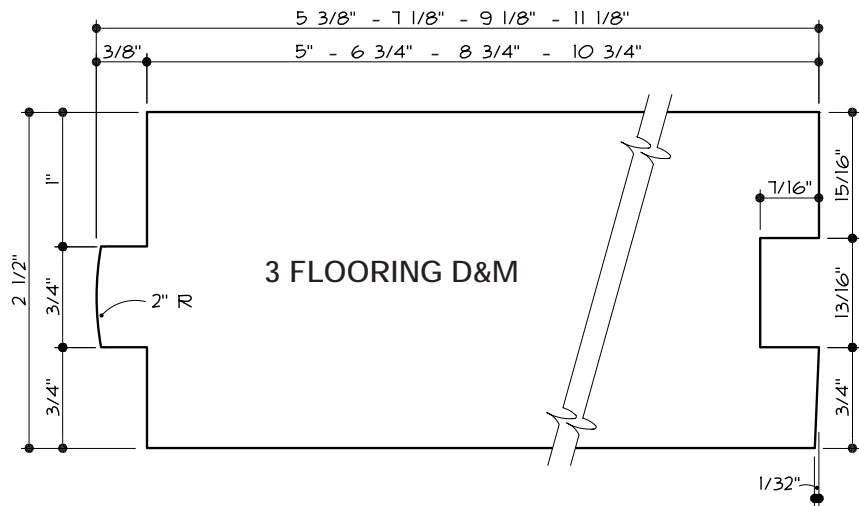
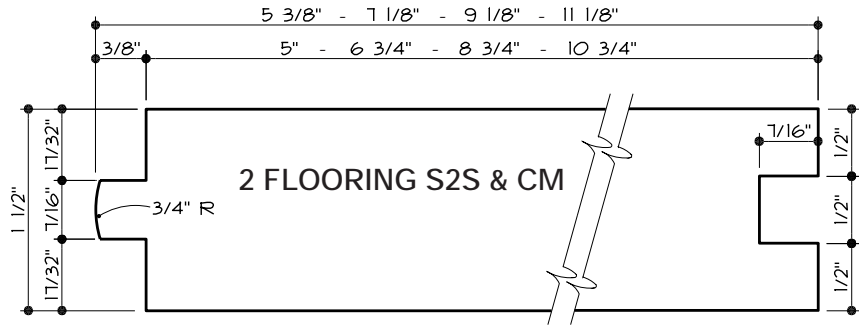
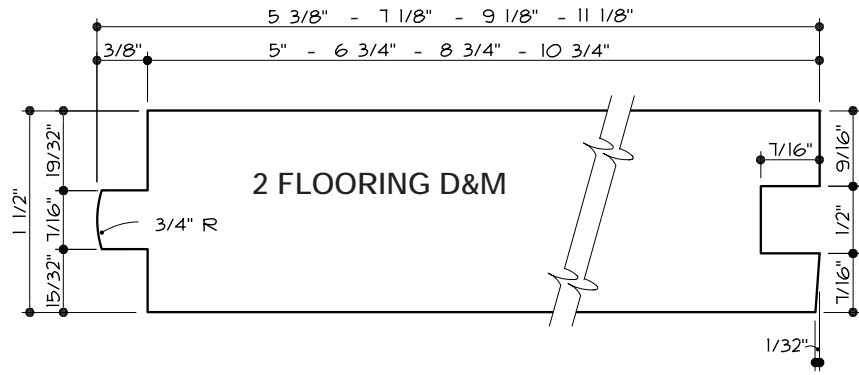

Corn Cribbing

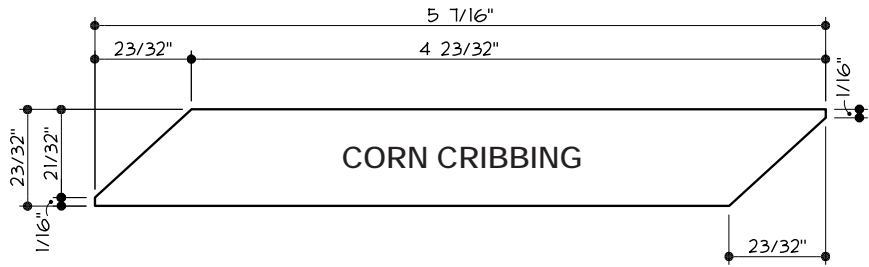

Grooved Roofing

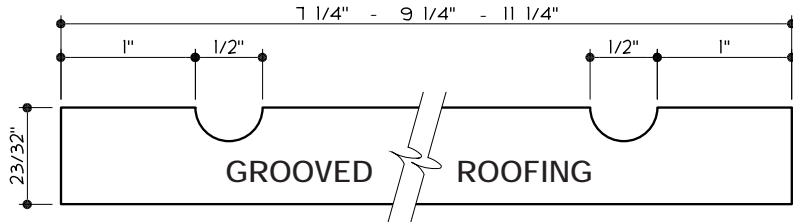

Patent Lath

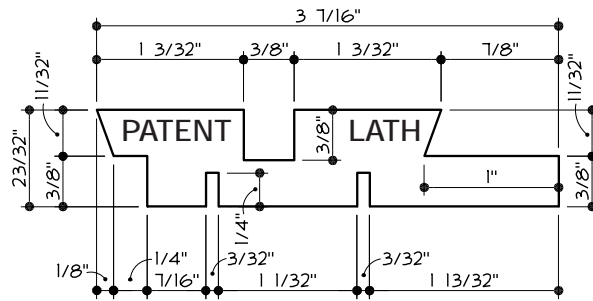

Stile

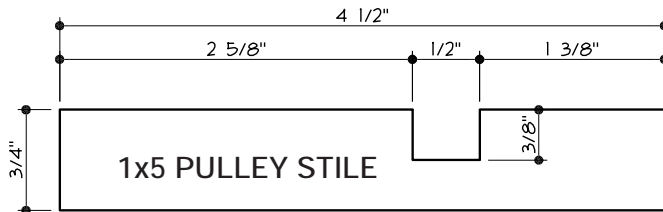

Sill

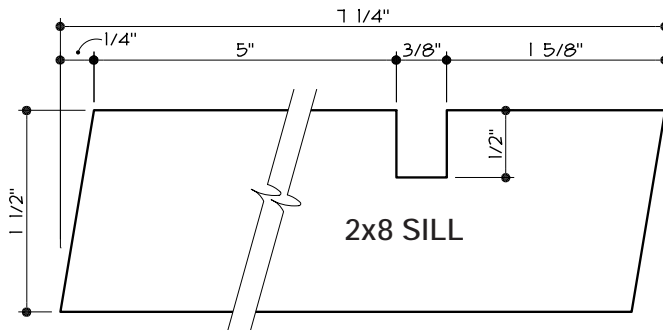

Jamb

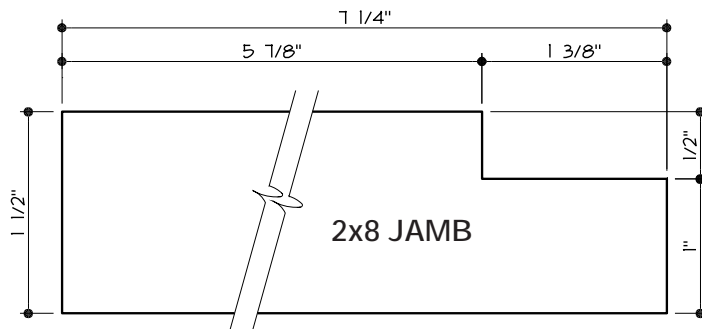

Ogee Batten

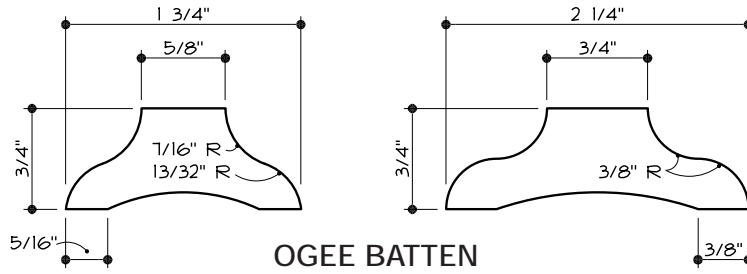

Casket Stock

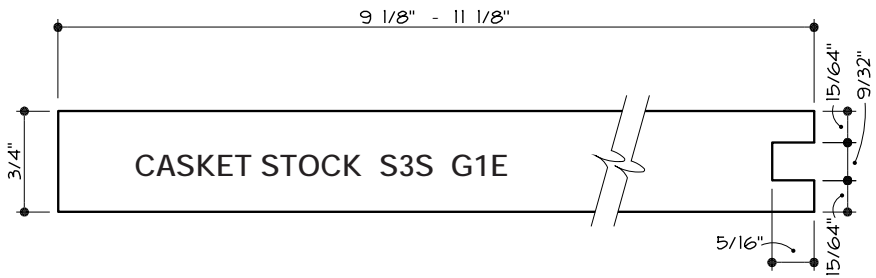
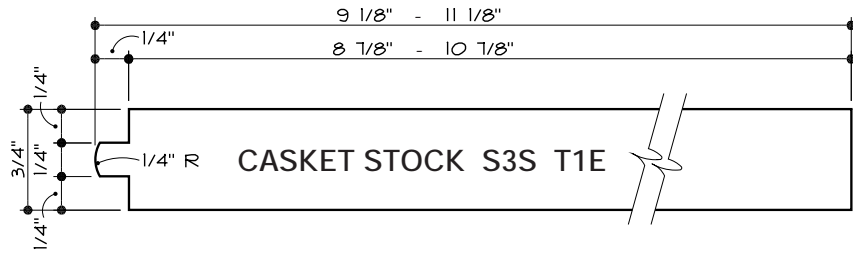

Beaded Shelving

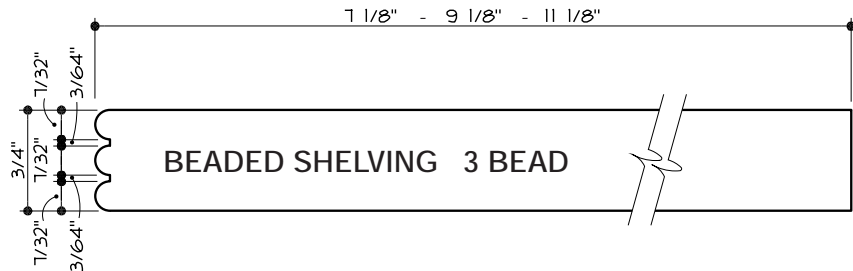
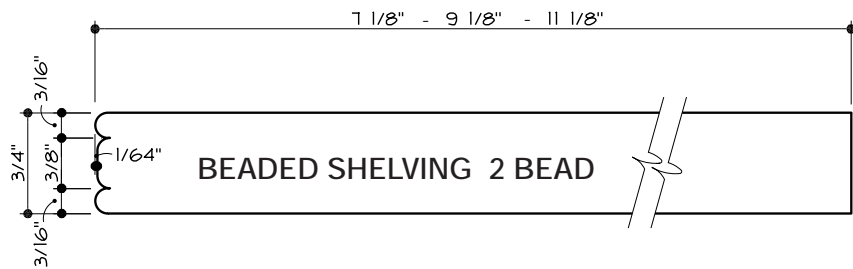

Unseasoned Tongued & Grooved

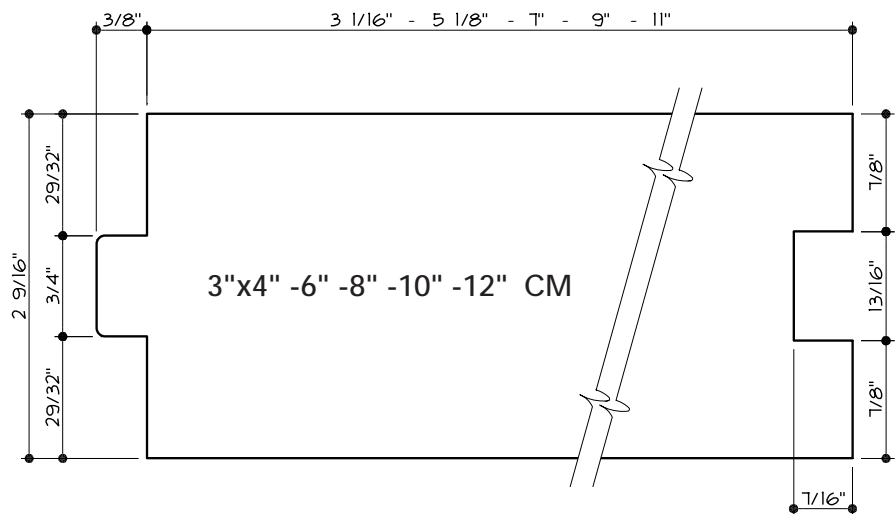
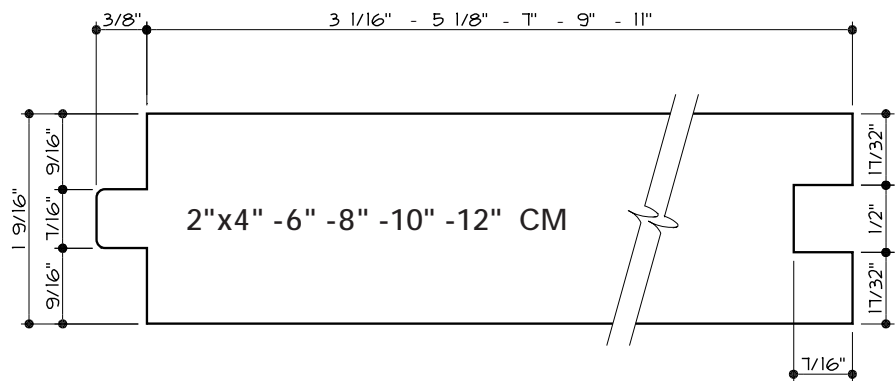
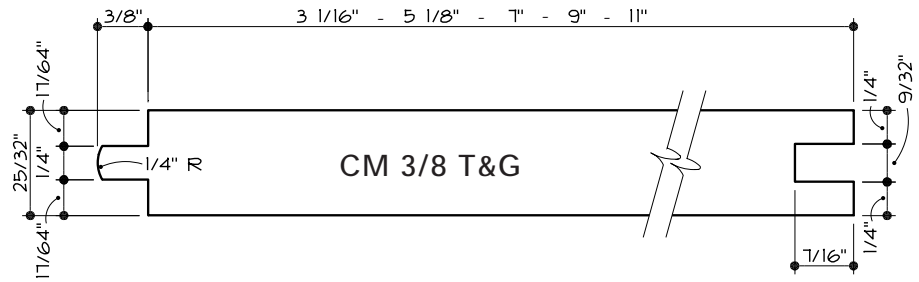
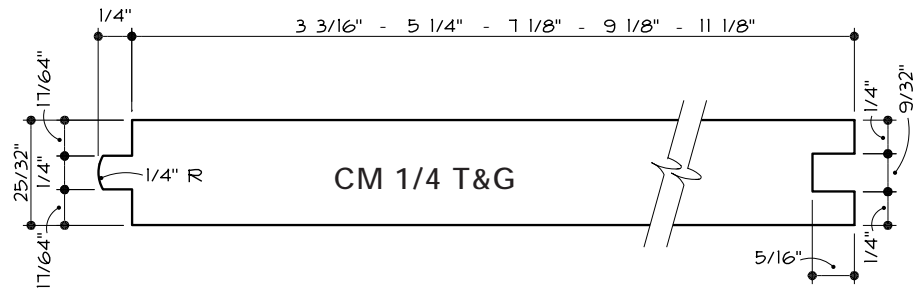

Unseasoned Tongued & Grooved

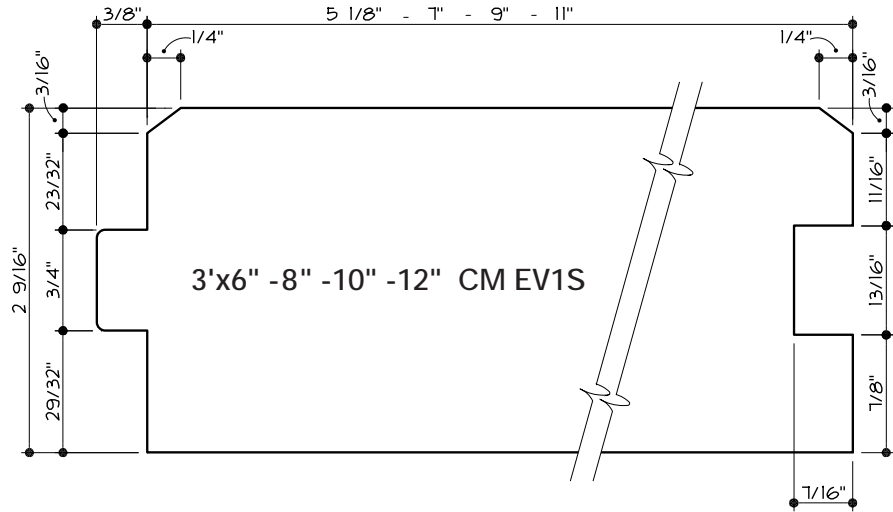
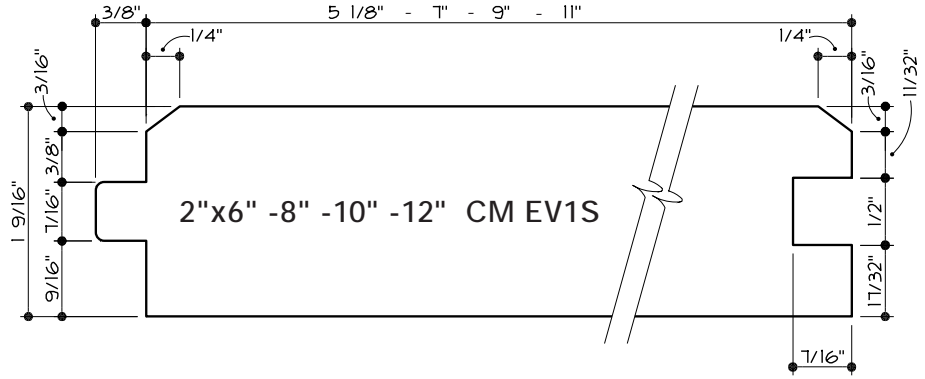

Unseasoned Shiplap

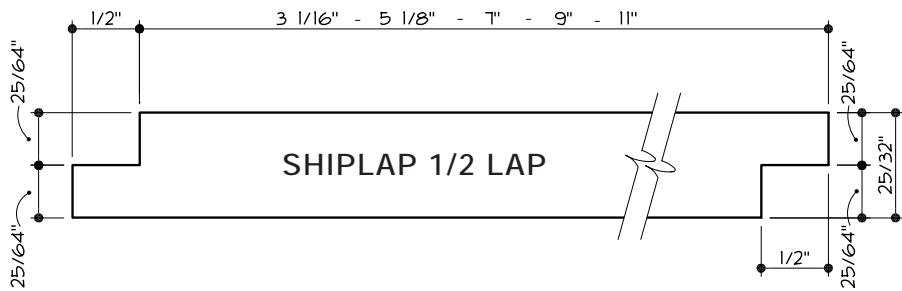
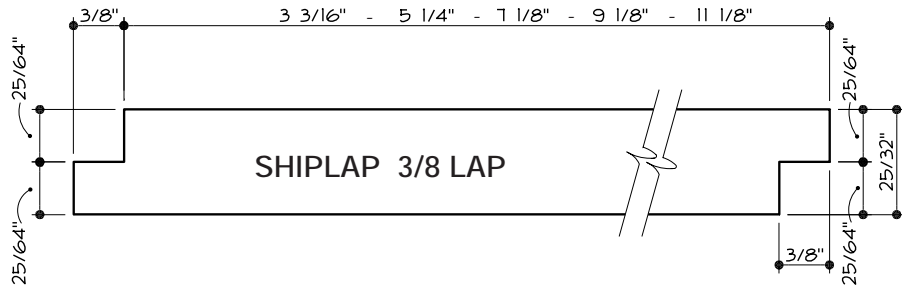

Unseasoned Shiplap

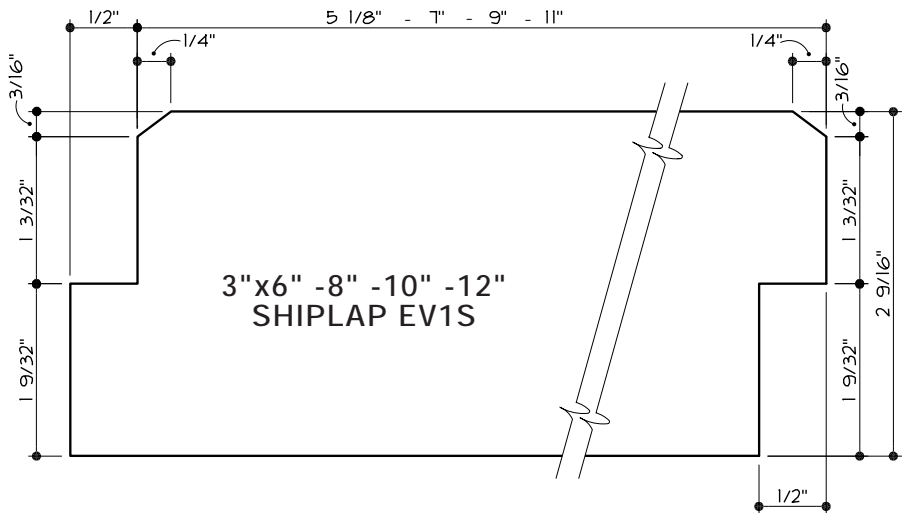
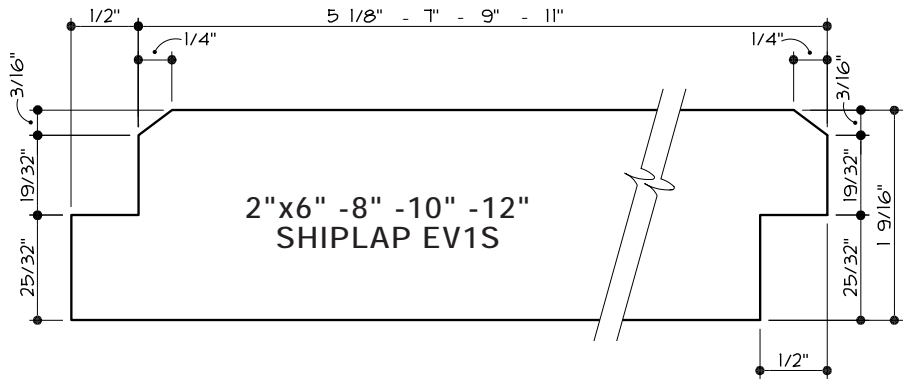
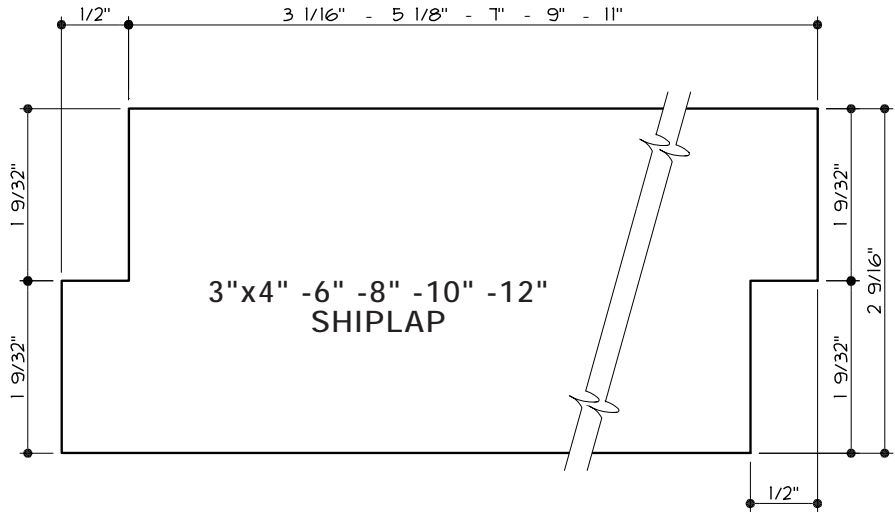
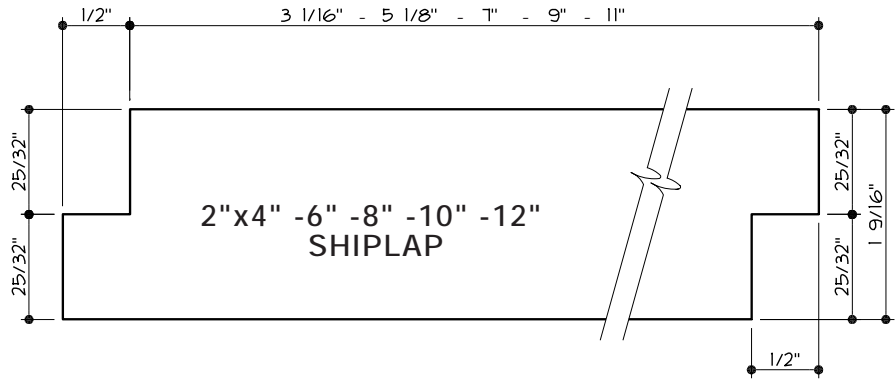

Coverage Calculations

Siding and paneling are usually sold either by the lineal (*running*) foot or by the board foot.

To simplify cost and coverage estimations, select the appropriate factor from the table at right according to how the material is priced. The factors provided in the table can be used to calculate the amount of siding required either in lineal feet or in board feet.

In either case, the square footage of the area to be covered is calculated first, then multiplied by the appropriate factor.

Procedure:

- A) Calculate the square footage in walls:
length x width = sq. ft.
- B) Calculate, and then subtract, the square footage of openings. Now add 10% for trim and waste.
- C) Multiply the result by either the factor for lineal feet **or** the factor for board feet.
- D) Multiply the total footage required by price.

Additional Information

Additional information and titles referenced in this publication are available for purchase from WWPA.

For a full description of technical publications available and a printable order form, go to the WWPA Internet site at www.wwpa.org.

You also can receive an order form via fax through the WWPA Fax Delivery Service by calling 732-544-2876 and following the instructions.

COVERAGE ESTIMATOR

Pattern	Nominal Width	Width		Factor for Lineal Feet ¹	Factor for Board Feet ²
		Dressed	Exposed Face		
Bevel & Bungalow	4	3½	2½	4.8	1.60
	6	5½	4½	2.67	1.33
	8	7¼	6¼	1.92	1.28
	10	9¼	8¼	1.45	1.21
Dolly Varden	4	3½	3	4.0	1.33
	6	5½	5	2.4	1.2
	8	7¼	6¾	1.78	1.19
	10	9¼	8¾	1.37	1.14
Drop, T&G and Channel Rustic	12	11¼	10¾	1.12	1.12
	4	3⅞	3⅞	3.84	1.28
	6	5⅞	5⅞	2.34	1.17
	8	7⅞	6⅞	1.75	1.16
Log Cabin	10	9⅞	8⅞	1.35	1.13
	6	5⅞	4⅞	2.43	2.43
	8	7⅞	6⅞	1.81	2.42
Boards	10	9⅞	8⅞	1.39	2.32
	2	1½			
	4	3½			
	6	5½			
	8	7¼			
	10	9¼			

¹ Lineal Foot Factor is derived by dividing 12" by the exposed face width.

² Board Foot Factor is derived by dividing the nominal width by the exposed face width and is based on nominal 1" stock, except log cabin. Log cabin is based on 2" thickness. For nominal 1½" log cabin, multiply by .75.

Note: Factors do not include any allowance for trim or waste and do not apply to diagonal installations. A 10% allowance (for trim and waste) should be added to the square footage required before the factors are used. Refer to *Procedure* at left.

Checklist for a Siding Material Specification

- Select species suited to the project.
- List grade names, paragraph numbers and rules-writing agency. (Refer to Grade Selector chart on back cover).
- Specify surface texture for exposed face.
- Specify moisture content suited to the project.
- If gradestamped, specify lumber to be stamped on back or ends. (WWPA's *Specifying Lumber* [A-2] offers additional information.)
- Specify VG (vertical grain) if appropriate and available.
- Specify pattern and size (WWPA's *Natural Wood Siding* [TG-8] and *Paneling Basics* [A-3] offer additional information.)

Western Lumber Grades

GRADE SELECTOR CHART-ALL SPECIES							
General Categories <i>(Note that there are additional grades for bevel pattern.)</i>		GRADES			Grade Rule Paragraph Reference & Specifying		
		WESTERN SPECIES		CEDAR Western & Canadian	WWPA ²	WCLIB ³	NLGA ⁴
		Selects ¹	Finish				
All Patterns	Premium Grades	B&Better (IWP Supreme)	Superior Prime	Clear Heart⁵	20.11	102-b	200a
		C Select⁵ (IWP Choice)		A Grade⁵	10.11	-	-
		D Select⁵ (IWP Quality)		B Grade	20.12	102-c	200b
Additional Grades for Bevel Patterns	Premium		Superior Bevel	Clear VG Heart⁵	21.11	106-aa	201a
				A Bevel⁵	21.12	106-a	201b
				B Bevel	16.11	-	-
	Knotty		Prime Bevel	B Rustic	21.13	106-b	201c
				C Bevel	-	-	201d
				Select Knotty⁶ Quality Knotty⁶	21.14	106-c	201e
All Patterns	Knotty Grades	Commons¹	Alternate Boards	Cedar	30.11 30.12 118-b - - 30.13 118-c 30.14 30.15	118-a 118-b 111-e 111-f - 118-c 118-d 118-e	114a 114b 204a 204b - 114c 114d 114e
		1 Common (IWP Colonial)	Select Merch. Construction	Select Knotty⁶ Quality Knotty⁶			
		2 Common (IWP Sterling)					
		3 Common (IWP Standard)	Standard Utility Economy				
		4 Common (IWP Utility)					
		5 Common (IWP Economy)					

1 Equivalent grades, under the same paragraph numbers in WWPA Rules, are available in Idaho White Pine. Refer to *Western Lumber Grading Rules*.
2 Western Wood Products Association's *Western Lumber Grading Rules*.
3 West Coast Lumber Inspection Bureau's *West Coast Lumber Standard Grading Rules*.
4 National Lumber Grades Authority's *Standard Grading Rules for Canadian Lumber*.
5 Some clear grades may be specified VG (vertical grain). Common practice is to ship orders as a combination of vertical and flat grain, unless specified otherwise.
6 The widely used marketing term, "STK" usually describes a combination of Select Knotty and Quality Knotty, sometimes marketed with approximately 15% of the order in Quality Knotty.
The grade names in bold face type are the most widely available grades. These are often specified as a grade combination that includes some portion of material in the next higher grade; i.e. C&Btr Select, D&Btr Select, A&Btr Cedar, 2&Btr Common, 3&Btr Common or Std&Btr (Standard & Better).



WESTERN WOOD PRODUCTS ASSOCIATION

522 SW Fifth Avenue, Suite 500
 Portland, OR 97204-2122
 tel: 503-224-3930 e-mail: info@wwpa.org
 fax: 503-224-3934 web site: www.wwpa.org

